



SPECIAL MEETING OF THE GOVERNING BODY RICE, TEXAS

Thursday, October 17, 2024

6:00 PM

Rice City Hall

305 N. Dallas Street

Rice, TX 75155

“The Rice City Council reserves the right to adjourn into Executive Session at any time during the course of this meeting to discuss any of the matters listed in this agenda, as authorized by Texas Local Government Code Sections 551.071 (*Consultation with City Attorney*), 551.072 (*Deliberations about Real Property*), 551.073 (*Deliberations about Gifts and Donations*), 551.074 (*Personnel Matters*), 551.073 (*Deliberations about Security Devices*) and 551.086 (*Economic Development*).”

AGENDA

1. Call to Order

**City of Rice
Mission Statement**

The City of Rice will maximize the opportunities for social and economic development while retaining an attractive, sustainable and secure environment for the enjoyment of the residents and visitors. Through unified responsible and professional leadership and partnership with others, the Municipality will strive to improve the quality of life for all.

2. Roll Call

- a. Sheila Teague
- b. Rosa Vasquez
- c. Nick White
- d. Donnie P. Fisher
- e. Troy Foreman
- f. Mayor Christi Campbell

3. Pledge of Allegiance

The Pledge of Allegiance to the Flag

"I pledge allegiance to the Flag of the United States of America, and to the Republic for which it stands, one Nation under God, indivisible, with liberty and justice for all."

4. Texas Pledge of Allegiance

The Pledge of Allegiance to the Texas State Flag

"Honor the Texas flag; I pledge allegiance to thee, Texas, one state under God, one and indivisible.

5. Prayer

6. Public Forum

7. Administrative Reports

- a. September 2024 Rice Volunteer Fire Department
- b. September 2024, Rice Police Department
- c. September 2024, Municipal Court
- d. September 2024, Administrative Report
- e. September 2024, EDC Updates
- f. September 2024, Mayors Report/Updates

8. Consent Items

- a. Discuss and Deliberate approval of the minutes from September 12, 2024 regular city council meeting
- b. Discuss and Deliberate approval of September 2024 financial report

9. New Business

- a. Presentation of Fall Festival check to Rice Volunteer Fire Department
- b. Discuss and Deliberate approval of disposing city property
- c. Discuss and Deliberate adopting Resolution 2024-10-17: Policy mandated by government.
- d. Discuss and Deliberate ordinance for No-Thru Traffic. This will help prevent trucks coming through town when there is an incident on I-45.
- e. Discuss and Deliberate approving a date for a workshop

10. Old Business

- a. Discuss and Deliberate approval of purchasing of road maintenance equipment
- b. Discuss and Deliberate the purchase/financing of a new patrol unit

11. Motion of Adjourn

I hereby certify that the above notice of meeting was posted on the bulletin board of City Hall, City of Rice, Texas, a place readily accessible to the public at all times, on the _____ day of _____, 2024 by 5:00 p.m., and remained posted for at least 72 continuous hours preceding the scheduled time of said meeting.

Name _____ Title _____



7. ADMINISTRATIVE REPORTS

Rice Volunteer Fire Department

Rice Police Department

Municipal Court

Administrative

EDC Updates

Mayors Report/Updates



**Rice Volunteer
Fire Department**
P.O. BOX 27 RICE, TX 75155

Rice Volunteer Fire Department had monthly meeting for September 2024.
Our current membership is 10 active members with a total approximately 23 members.

Rice Volunteer Fire Department responded to 28 calls for service in September 2024.

- Medical Emergency – 12 1- Emhouse- 2 – Chatfield
- Motor Vehicle Accident – 7 – 1 – Chatfield
- Grass Fire – 4 – 1- Emhouse – 1 – Chatfield
- Gas leak – 1
- Fire Investigation – 1
- Lift Assist – 1
- Vehicle Fire – 1
- Burn Ban – 1

Rice VFD had training in September.

Rice VFD 15 Fire Department personnel participated in the City Fall Festival.

Gaylon Taylor
Fire Chief
Rice VFD



Rice Volunteer Fire Department

11h · 🌐

...

Here are the calls for service through September 2024. Our volunteers have donated more than 3,000 hours so far this year.

9/30/2024

Rice Fire Rescue



	2021	2022	2023	2024
Structure	11	11	12	12
Vehicle Fire	12	3	20	12
MVA	34	27	55	44
Grass	23	41	56	33
Invest	3	9	10	8
EMS	5	2	21	123
Line Down	1	0	6	6
Haz Mat	1	2	0	2
Fire Alarms	5	3	4	4
Flase Alarms	0	0	1	2
Landing Zone	2	0	4	9
Mutual Aid	0	2	1	0
Total Calls	97	100	191	255
			Volunteer Hrs	3075
			City	138
			County	117

POLICE REPORT

FOR



RPD

September 2024



ARRESTS

5

CHARGES

Driving While Intoxicated w/ Child	1
Driving While Intoxicated	1
Driving While Intoxicated w/ Open Container	1
Possession of Controlled Substance	2
Evading with a vehicle	1
Warrant	1
<hr/>	<hr/>
Total	7

CRASHES

MVA	5
CMVA	1

<u>Calls For Service:</u>	<u>72</u>
<u>White Warrants:</u>	<u>01</u>
<u>Open Records Requests:</u>	<u>06</u>
<u>Municipal Court Cases Filed</u>	<u>104</u>
<u>CPS Reports:</u>	<u>02</u>
<u>Traffic Stops</u>	<u>293</u>
<u>Violations</u>	<u>428</u>
<u>Compliments</u>	<u>01</u>

Updates Regarding PD

- **September NIBRS Report submitted to DPS**
- **Delivered Meals on Wheels every Thursday.**
- **DPS CJIS Audit was completed, with NO Non-Compliance issues.**
- **Unit 108 was in the shop for a week due to Recall work. (Rear axle bolts)**
- **Unit 107 was in the shop for a week due to the front CV axle leaking grease.**
- **We are down to the 2 oldest vehicles in the Fleet at the time of this report.**

AUDIT CONDUCTED BY: Chief Charles Parson 10-03-2024

OffenseStopCount

*This report does not include voided, test, or deleted records, but does include warnings (if *ALL* or WARNINGS is selected in the Stop Result field.*

	293 Stops	428 Violations
	293 Stops	428 Violations
Speeding		129
Expired Registration		105
Defective Head Lamps		1
Defective Stop Lamps		1
Disregarded Traffic Control Device		3
Drove Without Lights When Required		1
Fail To Maintain Financial Responsibility		36
Fail To Stop-Designated Point-Stop Sign		1
Failed To Signal Lane Change		8
Illegal Pass On Right		1
Illegal Window Tint		18
No Drivers License		35
No Seat Belt - Passenger		1
Possession of Drug Paraphernalia		4
Ran Stop Sign		8
Unapproved Lighting		2
Defective Equipment		1
Display Fictitious License Plate		3
DOG OR CAT AT LARGE		1
Drive While License Invalid		10
Fail To Display Drivers License		1
Failed To Drive In Single Lane		9
Failed To Signal Distance Before Turn		1
Failed To Use Proper Headlight Beam		1
FAILURE TO REGISTER DOG OR CAT		1
Missing License Plate		7
No License Plate Light		1
No Tail Lamps		2
Obstruction Of View		1



OffenseStopCount

Possession or Purchase of Tobacco Product Under Legal Age Requirement	2
Expired Drivers License	5
FTYROW To Emergency Vehicle	1
Child (4-14) Not Secured By Seat Belt	1
Defective Tail Lamps	1
Unrestrained Child-Safety Seat Violation	3
Driving Wrong Side Of Road	1
Drove Onto Or Off Controlled Access Hwy Where Prohibited	9
Fail To Control Speed	1
Failed To Yield Right Of Way	2
Fictitious LP/Reg/Si	1
Impeding Traffic	1
Improper Passing	1
Operate Unregistered Motor Vehicle	1
Texting While Driving	1
Unsecured Load	1
Display Unclean License Plates	1
Drove Wrong Way On One-Way Roadway	1
Failed To Yield At Yield Intersection	1

Compliment

Charles Parson

From: Derek Cafferata <dkcafferata@allstateff.com>
Sent: Thursday, September 5, 2024 11:29 AM
To: Charles Parson
Cc: Maelene Dolores; dsmith@ricetx.gv; William
Subject: THANK YOU

Dear Sir,

I would like to personally thank you on behalf of my wife and myself for the dedication and professionalism that both Officer Delores and Officer Smith demonstrated on Saturday. Specifically, our tire became flat on I45 and we had to pull off the highway. Within 5 minutes, Officer Delores pulled up and asked if we required assistance. Due to the jack not being operable, Officer Smith was summoned and both officers successfully changed our tire in 100F weather.

Officers Delores & Smith in the eyes of my wife and myself are superstars and you should be extremely proud of their behavior and dedication.

Sincerely,

Derek

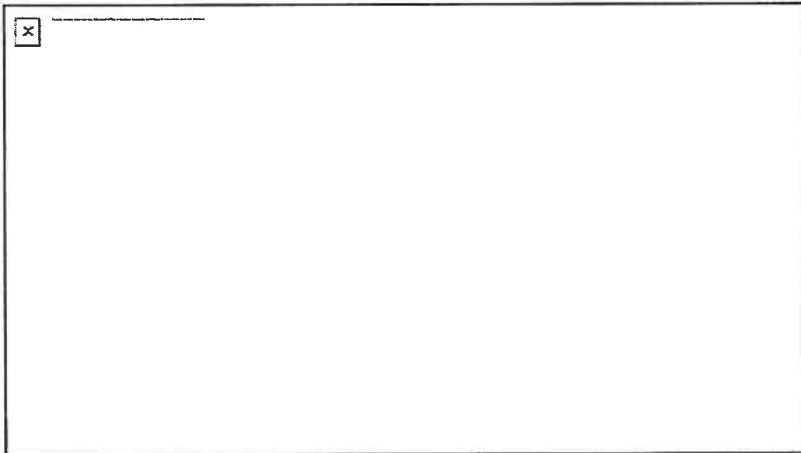

This message and any attachments are intended only for the use of the addressee and may contain information that is privileged and confidential. If the reader of the message is not the intended recipient or an authorized representative of the intended recipient, you are hereby notified that any dissemination of this communication is strictly prohibited. If you have received this communication in error, notify the sender immediately by return email and delete the message and any attachments from your system.

NIBRS Flat File Upload Error Report

Submitting Agency TX1750300 - RICE PD
Submitting User Charles Parson
File Name NIBRS REPORT SEPTEMBER 2024.txt
Total Incident Count 6
Valid Incident Count 5
Invalid Incident Count 1
Error Rate 16.67%
File Submission Date 10/2/2024 5:51:00 PM

Type	IdentifyingNumber	Agency	ErrorNumber	ErrorDescription
Incident	2416091	TX1750300 - RICE PD	304	The Description (1) in the Property Segment must contain a valid data value when it is entered; blank is permissible on non-mandatory fields. If Data Element 14 (Type Property/Loss/Etc.) is 2=Burned, 3=Counterfeited/ Forged, 4=Destroyed/Damaged/Vandalized, 5=Recovered, 6=Seized, or 7=Stolen/Etc., Data Elements 15 through 22 must have applicable entries in the segment.
Incident	2416091	TX1750300 - RICE PD	372	At least one Data Element 15 (Property Description) code must be entered when Data Element 14 (Type Property Loss/Etc.) contains Property Segment(s) for:2=Burned3=Counterfeited/Forged4=Destroyed/Damaged/Vandalized5=Recovered6=Seized 7=Stolen/Etc.
Incident	2416091	TX1750300 - RICE PD	375	

v5.9.4 On-Premise Assessment



Audit Complete

Rice Police Department (TX1750300)

Report created: Tue Oct 01 2024 11:46:42 GMT-0500 (Central Daylight Time)



Texas Department of Public Safety
Law Enforcement Support
Crime Records Service
PO Box 4143
Austin, Texas 78765-4143

Assigned By: (FA) William Frame - On: 8/20/2024

Submitted By Charles Parson on 8/22/2024	Submission Reviewed By (FA) William Frame on 10/1/2024	Compliance Report By N/A
Agency Response By (FA) William Frame on 10/1/2024	Final Report By (FA) William Frame on 10/1/2024	Confirmed Final Review By Confirmation Not Required

Please review each item and provide a response on how it will be addressed by the agency.

Compliance Report

Final Review Notes

None

Local Agency Review: October 1, 2024

Report Summary

FW: GovDeals Seller's Certificate: 92-0926241706-4294

From Charles Parson <cparson@ricetx.gov>
Date Thu 9/26/2024 4:09 PM
To Vicki Fisher <vfisher@ricetx.gov>

Mrs. Fisher,

Here is the information from GOV Deals. The Buyer should be contacting City Hall soon. Also the Salvage Title is here at the PD.

Think Healthy, Be Healthy.
Best regards,

Chief Charles Parson
Rice Police Department
305 N. Dallas Street
Rice, TX 75155
903-326-4146
903-326-7426 fax
cparson@ricetx.gov



[Matthew 5:9 Blessed are the peacemakers, for they shall be called the children of God.](#)

CONFIDENTIALITY NOTICE: The information contained in this electronic mail (e-mail) is confidential and/or privileged. This e-mail is intended to be reviewed initially by only the individual named above. If the reader of this page is not the intended recipient or a representative of the intended recipient, then s/he is hereby notified that any review, dissemination, or copying of this e-mail and the information contained herein is prohibited. If this e-mail has been received in error, please notify the sender, then delete the e-mail.

From: ClientServices@GovDeals.com <ClientServices@GovDeals.com>
Sent: Thursday, September 26, 2024 4:08 PM
To: Becky Funes <bfunes@ricetx.gov>
Cc: Charles Parson <cparson@ricetx.gov>; James Alsup <cityadministrator@ricetx.gov>
Subject: GovDeals Seller's Certificate: 92-0926241706-4294

Congratulations, Rice, TX has sold another item on the GovDeals Auction Server.

BUYER (#2869474)	SELLER (#4294)
------------------	----------------

Name:	nickolas mcallister	Agency:	Rice, TX
Company:	mcallister,nickolas	Contact:	Becky Funes
Title To:	nickolas mcallister	Phone:	903-326-7500
Phone:	850-939-0604	Fax:	903-326-7106
Email:	icaretransportrental@gmail.com	Email:	bfunes@ricetx.gov
Address:	1920 N Coit Rd Ste 200 PMB 158 Richardson, TX 75080-2842	Address:	305 N Dallas St Rice, TX 75155

ITEM INFORMATION FOR ASSET ID: 92			
Item:	2019 Ford Explorer		
Pick Up Location:	305 N Dallas Street, Rice, TX 75155		
Inventory ID:	106	Account ID:	4294
Condition:	Used/See Description	Quantity:	1 each
Make/Brand:	Ford	Model:	Explorer
VIN/Serial:	1FM5K8AR4KGA20026	Model Year:	2019
Meter:	44,105 Miles	Title Restrictions:	Yes: Salvage Title

Date	Item		Amount
26 Sep 2024 04:06 PM CDT	2019 Ford Explorer		USD \$1,825.00
	Buyer's Premium	12.5000000000%	USD \$228.12
		Total	USD \$2,053.12

Payment Instructions:

Wire Transfer is the only payment option for this item. The Wire Transfer Transaction Summary page will provide payment and account information. The Wire Transfer must be completed within 5 days unless otherwise specified below.

PAYMENT

If you are the winning bidder, you will facilitate payment by referring to the [My Bids](#) section of your account.

Note:

1. Payment is due within 5 (five) business days of auction closure.
2. Any invoice \$5,000 or above requires payment via wire transfer.
3. Depending on your history with GovDeals, you may be limited to the number of auctions/transactions that you can participate in simultaneously AND/OR the dollar amount that you can pay via credit card, debit card or PayPal. For additional insight, please visit the [Probation FAQ](#).

SALES TAX

When applicable, sales tax is calculated based upon the auction's advertised location.

If you are seeking sales tax exemption, you must complete Liquidity Services' tax exemption form(s). We recommend doing this prior to the auction's closure or before making payment. To do so, please visit [Liquidity Services' Tax Exemption Submission Tool](#).

Removal Instructions:

Property may be removed by appointment only and appointments must be made at least 24 hours in advance. All items must be removed within ten (10) business days from the time and date of issuance of the Buyer's Certificate.

The Buyer will make all arrangements and perform all work necessary, including packing, loading and transportation of the property. No Assistance will be provided. A daily storage fee of \$10.00 may be charged for any item not removed within the 10 business days allowed and stated on the Buyer's Certificate.

Special Instructions:

If you are the winning bidder and default by failing to adhere to this sellers terms and conditions your account with GovDeals WILL BE LOCKED

<br.< b="">

Guaranty Waiver: All property is offered for sale "AS IS, WHERE IS." (Seller) makes no warranty, guaranty or representation of any kind, expressed or implied, as to the merchantability or fitness for any purpose of the property offered for sale. The Buyer is not entitled to

any payment for loss of profit or any other money damages – special, direct, indirect, or consequential.

Description:

2019 Ford Explorer SPORT UTILITY 4-DR, 3.7L V6 DOHC 24V.

Starts and engine runs

Transmission - operable - needs repair: transmission cooler is busted, leaking fluid

All wheel drive

Cracked glass

Tires - good

Damages to front and rear end

Normal wear to interior

Radio - stock - AM/FM CD

AC - unknown

Cruise control - tilt steering - remote mirrors - climate control

Power : steering - windows - door locks - seats

Unit 106

Rice, TX
305 N Dallas St
Rice, TX 75155

Bill of Sale Date: 26 Sep 2024
Asset ID: 92

Bill of Sale ID: 926202492
Inventory ID: 106
Award Amount: \$1,825.00 USD

Asset Information



Description: 2019 Ford Explorer VIN/Serial: 1FM5K8AR4KGA20026
Year: 2019 Make/Brand: Ford Model: Explorer Meter: 44105 Miles (Accurate?: Yes)
Body: SPORT UTILITY 4-DR Trim: Police 4WD Color: Title Restriction: Yes: Salvage Title

Sale Information

Actual Sold Amount: \$1,825.00 USD Paid On: 03 Oct 2024 Wire Transfer
Other Amount: \$0.00 USD Other Amount Description:
Buyer's Premium: \$228.12 USD
Total Amount: \$2,053.12 USD

Buyer Information

nickolas mcallister
1920 N Coit Rd Ste 200 PMB
158
Richardson, TX 75080-2842
USA
icaretransportrental@gmail.com
8509390604

Asset is sold as is, where is and without warranty. Once the asset is removed from the seller's premises there is no refund of monies previously paid.

Buyer/Agent Signature: _____
Print Name: _____
Date: _____

FW: govdeals.com Payment Received

From Charles Parson <cparson@ricetx.gov>

Date Thu 10/3/2024 10:50 AM

To Vicki Fisher <vfisher@ricetx.gov>; Sharon Watkins <swatkins@ricetx.gov>

Cc Mathew Adams <madams@ricetx.gov>; Celeste Martinez <cmartinez@ricetx.gov>

 1 attachments (26 KB)

BillOfSale_4294_92.pdf;

Team Rice,

The Buyer has paid for Unit 106.

Think Healthy, Be Healthy.

Best regards,

Chief Charles Parson

Rice Police Department

305 N. Dallas Street

Rice, TX 75155

903-326-4146

903-326-7426 fax

cparson@ricetx.gov



Matthew 5:9 Blessed are the peacemakers, for they shall be called the children of God.

CONFIDENTIALITY NOTICE: The information contained in this electronic mail (e-mail) is confidential and/or privileged. This e-mail is intended to be reviewed initially by only the individual named above. If the reader of this page is not the intended recipient or a representative of the intended recipient, then s/he is hereby notified that any review, dissemination, or copying of this e-mail and the information contained herein is prohibited. If this e-mail has been received in error, please notify the sender, then delete the e-mail.

From: ClientServices@GovDeals.com <ClientServices@GovDeals.com>

Sent: Thursday, October 3, 2024 8:56 AM

To: Becky Funes <bfunes@ricetx.gov>

Cc: Charles Parson <cparson@ricetx.gov>; James Alsup <cityadministrator@ricetx.gov>

Subject: govdeals.com Payment Received

Payment has been received for the following asset. The buyer has been notified that the payment has been received. They have been instructed to contact you concerning pickup of the

asset. The buyer should present you with the buyer certificate at pickup.

Please print a copy of the Bill of Sale (attached) for each of these assets and have the Buyer sign the Bill of Sale upon removal, or you can log into <https://cf.govdeals.net> to print the Bill of Sale.

Thank you for using GovDeals.

Buyer: nickolas mcallister (username: reshay0287) icaretransportrental@gmail.com

The following asset is ready for pickup:

Certificate ID: 92-0926241706-4294

Asset ID: 92

Inventory ID: 106

Description: 2019 Ford Explorer

If you have any questions, please contact your Client Account Manager, Ashley Veltjes at 3343003869.

City of Rice
Municipal Court Council Report
From 9/1/2024 to 9/30/2024

10/7/2024 12:16 PM

Violations by Type

Traffic	Penal	City Ordinance	Parking	Other	Total
342	0	2	0	6	350

Financial

State Fees	Court Costs	Fines	Tech Fund	Building Security	Total
\$22,424.24	\$19,553.52	\$27,887.25	\$1,023.01	\$1,212.73	\$72,100.75

Warrants

Issued	Served	Closed	Total
0	0	54	54

FTAs/NPTAs

FTAs	VPTAs	Total
0	0	0

Dispositions

Paid	Non-Cash Credit	Dismissed	Driver Safety	Deferred	Total
198	0	46	12	45	301

Trials & Hearings

Jury	Bench	Appeal	Total
0	0	1	1

Omni/Scofflaw/Collection

Omni	Scofflaw	Collection	Total
1	0	1	2

**September 2024
Administrative Report**

Municipal Clerk

- Began inventory of office space
- Closed month of September
- Closed fiscal year 2023-2024
- Double checking Bureau Veritas invoice against permits
- Makes deposits
- Looks over permit applications
- Calls in inspections
- Match Shell receipts to Shell invoice

City Secretary/Finance

- Began inventory of office space
- Reconciled month of September
- Closed month of September
- Closed fiscal year 2023-2024
- Input each employee's wages, insurance with new prices into Fundview
- Worked with Globe Life for sign ups
- Worked with Aflac sign ups
- Paid bills
- Keeps up with budget with each department
- Assists with City Council agenda

Public Works

Week of September 2-6

- Mowed around Beautification Project
- Reset timer for watering system
- Mowed on east side of I45
- Mowed Sherman Street
- Graded North and South Sherman Street
- Added 6 buckets of road base to Homer
- Mowed downtown for Fall Festiva
- Added 3 buckets of road base to Gilmer and graded
- Added 1 bucket of road base to Benton and graded
- Worked on deck of lawnmower

Week of September 9-13

- Mowed Farmers Market for Fall Festival
- Mowed city lots between Dallas and Lincoln

Pulled weeds from Beautification project
Ordered Stop signs and Mike Dickens Memorial Park sign
Continued inventory of compound
Put belt on back up mower and completed oil change on #1 mower
Worked on inventory of equipment and tools in compound
Picked up trash on 0140 and Capital T
Worked on preventative maintenance on equipment
Picked up downed trees on Fannin
Picked up trash on Fannin and East side service road
Bring trash cans to downtown for Fall Festival

Week of September 16-20

Continued work in compound; inventory and weedeating
Mowed and cleared around Beautification project
Mowed Farmers Market
Added 2 bucket loads road base to Fannin, packed and graded
Added 1 load of road base to 0140; graded and scattered

Week of September 23-30

Built street and stop signs
Added 2 buckets of millings on Sunrise Circle
Mowed around Beautification project
Added 3 buckets of millings on Dallas Street
Graded roads with millings
Added 1 bucket of millings on Dresden Street
Pulled weeds in Beautification project
Worked with police department to set up for National Night Out
Washed gator and tractor
Got in touch with Chad about roads and renting equipment and operator. Chad was out of town but will get back in touch

Parks and Recreation

Began inventory of office space and supplies
Worked with school for volunteers for Fall Festival
Got donations for Fall Festival
Set up vendors for the Fall Festival
Worked with Event Committee
Set up for Fall Festival
Worked Fall Festival-

Administrator Report

Began inventory of office space

Prepared agendas and packets

Worked with Tom on Road Repair Plans

6 Loads of Road base for Fannin

3-4 Loads of road base for 0140

4-5 loads of road base for Capital T

Will order millings after rock roads are repaired and a decision is made for equipment

Spoke with Charles at JR West about road repairs. He stated that he couldn't do anything without an engineer's report. They have an inhouse engineer but are about 1 month out with new jobs.

This is actually for the October report: Spoke with many vendors for road repairs, grants and financing. In the process of applying for a grant with Texas Department of Agriculture for infrastructure; in contact with a road repair company for the Zipper; sent the police units pricing to a financial institute.



8. CONSENT ITEMS

a. Discuss and Deliberate approval of the September 12, 2024 regular city council meeting

b. Discuss and Deliberate approval of the September 2024 financial report



**REGULAR MEETING OF THE GOVERNING BODY
RICE, TEXAS**

Thursday, September 12, 2024

6:00 PM

Rice City Hall

305 N. Dallas Street

Rice, TX 75155

1. Call to Order: Mayor Christi Campbell called meeting to order at 6 p.m.

2. Roll Call

- a. Sheila Teague: Present
- b. Rosa Vasquez: Present
- c. Nick White: Present
- d. Donnie P. Fisher: Present
- e. Troy Foreman: Present
- f. Mayor Christi Campbell: Present

3. Pledge of Allegiance: By All

4. Texas Pledge of Allegiance: By All

5. Prayer: Chief Charles Parson

6. Public Forum:

Valerie Rider.

Valerie Ryder brought information about a 19x38 storage building that she wanted to be built on sight on a piece of property in town. It is not a modular home. Wants City ordinance to be changed so that she can build it. She is selling her home and will be living in this home. Mayor stated that we will take this under consideration and discuss at later date.

Mayor allowed Curan Oakly to come up and speak.

Curan Alsup Oakley thanked the Mayor and City Council for allowing her to speak.

I have been a community member for over 49 1/2 years, 50 years in February. I have served my community in one way or another all my entire adult life. I have served The City of Rice as a police officer, on the event committee with Vickie Young. I have also partnered with the City with my current employer. I spend money in this town and although I don't live in the city. I am a vested member of this community. I want to see good things for Rice, and I've always wanted this. For the record this is not my first Council meeting. I have also attended a meeting with Commissioner Grant when he came to speak. Having said all of this it is disheartening to see our Mayor on a public Facebook page, having dialect with citizens and community members, that some find inappropriate. When you have this kind of dialogue with citizens. that it not only makes you look bad but the city as a whole look bad. Just don't take the bait. To call someone who has lived in this community and almost died fighting for it delusional, is very unbecoming of you. To suggest that someone sell their property within the city because they are not pleased with this or that, is sad. Please use your position as Mayor to have positive communication with your residence. Many residences use social media to keep track of what is going on in the community. We all know there are so many reasons why people don't come to city council meetings and that's really beside the point. Many have suggested that I run for Mayor. I always say I don't live in city limits but maybe just maybe I should rethink that because I guarantee that I will never talk down to your residents or community members that I have the pleasure to serve. I hope you take these words to heart and do better. Please note that I debated I really did debate whether I wanted to come tonight to speak, because I don't want to ruin my relationship with the city. The people in this room that know me know my heart. I hope you know the words come from my heart and you can do for the betterment of the community that we have all chosen to live in, and you were elected to serve. Thank you.

7. **Alderman Updates:** No Updates

8. **Reports:**

Motion to forego the reading of the reports made by Troy Foreman, and 2nd by Donnie P. Fisher.

Ayes: Troy Foreman, Donnie P Fisher, Sheila Teague, Rosa Vasquez, Nick White

Nays: None

Motion Passed

- a. August 2024 Volunteer Fire Department Report
- b. August 2024 Police Department Report
- c. August 2024 Municipal Court Report
- d. August 2024 Administrative Report
- e. August 2024 EDC Report
- f. August 2024 Mayor's Report

9. Consent Items

- a. Discuss and Deliberate approval of Minutes for Workshop on August 7, 2024.

Motion to Approve Minutes for Workshop on August 7, 2024, made by Donnie P. Fisher, and 2nd by Sheila Teague

Ayes: Donnie P. Fisher, Sheila Teague, Rosa Vasquez, Nick White, Troy Foreman.

Nays: None

Motion Passed

- b. Discuss and Deliberate approval of Minutes for Regular City Council meeting on August 8, 2024.

Motion to Approve the Minutes for Regular City Council meeting on August 8, 2024, made by Donnie P. Fisher and 2nd by Nick White.

Ayes: Donnie P. Fisher, Nick White, Sheila Teague, Rosa Vasquez, Troy Foreman.

Nays: None

Motion passed

- c. Discuss and Deliberate approval of Minutes for Workshop on August 13, 2024

Motion to Approve Minutes for Workshop on August 13, 2024, made by Troy Foreman, and 2nd by Sheila Teague.

Ayes: Troy Foreman, Sheila Teague, Rosa Vasquez, Nick White, Donnie P. Fisher

Nays: None

Motion Passed

- d. Discuss and Deliberate approval of Minutes for Special Meeting of the City Council on August 21, 2024

Motion to Approve the Minutes for Special Meeting of the City Council on August 21, 2024, made by Troy Foreman and 2nd by Sheila Teague.

Ayes: Troy Foreman, Sheila Teague, Rosa Vasquez, Nick White, Donnie P. Fisher

Nays: None

Motion Passed

- e. Discuss and Deliberate approval of Minutes for Special Meeting of City Council on August 26, 2024.

Motion to Approve the Minutes for Special Meeting of City Council on August 26, 2024, made by Troy Foreman, and 2nd by Sheila Teague.

Ayes: Troy Foreman, Sheila Teague, Rosa Vasquez, Nick White, Donnie P. Fisher

Nays: None

Motion Passed

- f. Discuss and Deliberate approval of August 2024 financial report.

Motion to Approve August 2024 Financial Report, made by Rosa Vasquez, and 2nd by Troy Foreman.

Ayes: Rosa Vasquez, Troy Foreman, Donnie P. Fisher, Sheila Teague, Nick White

Nays: None

Motion Passed

10. Public Hearing

- a. Public Hearing to consider the proposed 2024-2025 budget.

No Speakers.

- b. Public Hearing to consider the proposed tax rate for 2024-2025

- 1. Laura McGee

First off, I realize it is not a large tax increase, y'all have to realize that people are struggling they are really struggling. The appraisals are out of sight, foreclosures are up. Just the other day I talked to my banker, and he wanted to charge me 9% on a loan. How are people making it if they don't have a fixed rate on their mortgages. If these puppies have gone up this much are, I don't see how people are keeping up. The appraisals are outrageous, they say a 1-acre piece of land in Rice is \$45,000.00. That's higher than Mildred, that's higher than Corsicana, that's higher than any of the small towns around here. And we have the lowest median income of any of the towns around here. I want y'all to reconsider raising taxes. I think y'all perhaps have already decided on. You know I think since people are struggling so and that they are having to tighten their belts I think you should tighten yours. Ours are tight. Make yours tight. Our City government is pretty large for 1100 people. I got that off the US Census. When I left the City of Rice in 1999, there were approximately 800 people in Rice. Our city government consisted of Council which we know you are not paid, Administration was pretty much a City Secretary, a Court

Clerk, a Municipal Clerk, and a county Judge. And I believe just as I left, they brought on a prosecutor. That's it that was for 800 people. That was for 3 full-time officers and most of the time we carried 6 reserve officers. That's how we made it work in Rice. We used reserve officers and that was great because reserve officers, they could keep their license by being a reserve officer. Retired officers could keep their license, new officers get training could work as a reserve. There are other ways to do this besides just piling on more and more employees. Tighten your belts people, tighten your belts. That is really all I have to say. The last thing I want to say is

"The nine most terrifying words in the English language are, I'm from the Government and I'm here to help". Ronald Reagan, 8-12-86

Thank y'all for your time. You have a lovely evening.

2. J. Nicole Jackson

Good evening. I want to start off by thanking the Council and our staff for everything that you guys do every day and sacrificing your time to come in here and working on behalf of the city.

I'm coming as a citizen and realtor, to explain how we increase our taxes in our government and how it affects the little people. We have escrow in our mortgages and when the taxes increase, our mortgages increase. With the cost of food and the cost of everything going up, just making this small increase, can put someone into foreclosure. It is only adding about \$17000.00 to the budget. I have done the budget for three years, so I know there are things we can move around in the budget to be able to decrease. We decreased the taxes last year. Appraisals have gone up, which increases are income. We have new sales tax coming in with businesses coming in, which will increase our income. Every year we have had a surplus. So, I am asking you to consider what you are doing to the little people. I know its small to you guys on your budget, but on their mortgage every month, it's going to be a big increase. That's all I have to say. Thank you for your time.

Mayor Campbell closed out public hearing at 6:22 p.m.

11. New Business

a. Discuss and Deliberate approval of the 2024-2025 proposed budget.

Motion to approve the 2024-2025 proposed budget made by Troy Foreman, and 2nd by Nick White.

Ayes: Troy Foreman, Nick White, Rosa Vasquez, Sheila Teague, Donnie P. Fisher

Nays: None

Motion Passed

b. Discuss and Deliberate approval of the 2024-2025 proposed tax rate of 0.4105/100

Motion to approve the 2024-2025 proposed tax rate of 0.4105/100, made by Troy Foreman, and 2nd by Nick White.

Ayes: Troy Foreman, Nick White, Rosa Vasquez, Sheila Teague,

Nays: Donnie P. Fisher

Motion Passed

c. Discuss and Deliberate the disposal of Unit 106

Motion to authorize Chief Parson to dispose of unit 106 to the highest bidder, Made by Donnie P. Fisher, and 2nd by Troy Foreman.

Ayes: Donnie P. Fisher, Troy Foreman, Sheila Teague, Nick White,

Rosa Vasquez

Nays: None

Motion Passed

d. Discuss and Deliberate installing a Stop sign on E. Calhoun Street at the Northbound cloverleaf intersection for traffic traveling West on Calhoun.

Motion to install a Stop sign on E. Calhoun Street at the Northbound Cloverleaf intersection for traffic, traveling West on Calhoun Street, made by Rosa Vasquez, and 2nd by Sheila Teague.

Ayes: Rosa Vasquez, Sheila Teague, Nick White, Troy Foreman, Donnie P. Fisher

Nays: None

Motion Passed

e. Discuss and Deliberate installing two Stop signs on East Camden Street at the intersection of North Sherman Street for traffic traveling East and West on Camden.

Motion to approve placing two Stop signs on East Camden Street at the intersection of North Sherman Street for traffic traveling East and West on Camden, made by Donnie P. Fisher, and 2nd by Nick White

Ayes: Donnie P. Fisher, Nick White, Sheila Teague, Rosa Vasquez, Troy Foreman.

Nays: None

Motion passed

f. Discuss and Deliberate installing a Stop sign on North Dallas Street at the intersection of East Gilmer Street for traffic travelling South out of the new subdivision on Dallas Street.

Motion to approve installing a Stop sign on North Dallas Street at the intersection of East Gilmer Street for traffic travelling South out of the new subdivision on Dallas Street, made by Troy Foreman, and 2nd by Nick White.

Ayes: Donnie P. Fisher, Troy Foreman, Sheila Teague, Nick White, Rosa Vasquez

Nays: None

Motion Passed

g. Discuss and Deliberate the purchase of an Asphalt Roller

Motion to deny purchase of roller made by Donnie P. Fisher, and 2nd by Troy Foreman.

Ayes: Donnie P. Fisher, Troy Foreman, Sheila Teague, Nick White, Rosa Vasquez

Nays: None

Motion Passed

h. Discuss and Deliberate the purchase of a dump trailer.

Motion to table item on dump trailer to allow time to get more info until October meeting made by Donnie P. Fisher and 2nd by Troy Foreman.

Ayes: Donnie P. Fisher, Troy Foreman, Sheila Teague, Nick White, Rosa Vasquez

Nays: None

Motion Passed

i. Discuss and Deliberate the purchase/order a new patrol vehicle.

Motion to table until October to have time for Admin and Chief to get numbers for financing and pricing made by Troy Foreman, and 2nd by Nick White.

Ayes: Donnie P. Fisher, Troy Foreman, Sheila Teague, Nick White, Rosa Vasquez

Nays: None

Motion Passed

12. Motion to Adjourn

Motion to Adjourn made by Donnie P. Fisher and 2nd by Sheila Teague.

Ayes: Donnie P. Fisher, Sheila Teague, Nick White, Troy Foreman, Rosa Vasquez

Nays: None

Motion Passed.

Attest:

Date _____

Sharon Watkins, City Secretary/Finance Clerk

Summary

City of Rice
Bank Reconciliation Report Summary
9/1/2024 to 10/1/2024
FSB Consolidated Cash Checking 999-1000 Consolidated Cash Checking

Statement Beginning Balance		333769.96	Statement Ending Balance
Cleared Balance	Cleared Increases	124614.08	
	Cleared Decreases	<u>-95054.22</u>	
		363329.82	Adjusted GL Balance
	Uncleared Increases	0	0
	Uncleared Decreases	<u>0</u>	0
Statement Ending Balance	Remaining To Clear	0	363329.82 GL Ending Balance

	363329.82
Outstanding Increases	234 229209.45
Outstanding Decreases	75 <u>-179822.84</u>
	412716.43

Remaining To Reconcile	412716.43
	0

City of Rice Financial Statement As of September 30, 2024

100 - General Fund	Current Month Actual	Current Month Budget	Budget Variance	YTD Actual	Annual Budget	% of Budget	Budget Remaining
Revenue Summary							
Sales & Property Taxes	26,773.32	23,285.00	3,488.32	548,552.38	600,000.00	91.43%	51,447.62
Interest Income	0.00	106.85	(106.85)	11.36	2,500.00	0.45%	2,488.64
Business & Franchise	922.27	834.00	88.27	64,166.66	60,000.00	106.94%	(4,166.66)
Leases & Rents	8,111.99	5,770.00	2,341.99	75,540.22	53,600.00	140.93%	(21,940.22)
Other Revenue Sources	2,079.76	2,337.00	(257.24)	35,533.08	42,000.00	84.60%	6,466.92
Licenses & Permits	3,536.49	2,400.00	1,136.49	27,503.00	30,000.00	91.68%	2,497.00
Fines & Fees	36,619.17	25,251.00	11,368.17	393,779.57	305,000.00	129.11%	(88,779.57)
Court Revenues	9,243.29	5,565.50	3,677.79	86,063.43	72,000.00	119.53%	(14,063.43)
Checking Account Carry Forward Year End	0.00	16,740.00	(16,740.00)	0.00	200,000.00	0.00%	200,000.00
Revenue Totals	87,286.29	82,289.35	4,996.94	1,231,149.70	1,365,100.00	90.19%	133,950.30
Expense Summary							
Personnel/Payroll	62,969.36	61,446.19	1,523.17	743,994.17	782,785.91	95.04%	38,791.74
Office & Supplies	1,894.47	2,732.13	(837.66)	28,190.67	39,450.00	71.46%	11,259.33
Operating Expense	8,738.67	10,405.71	(1,667.04)	121,802.72	140,350.00	86.78%	18,547.28
Legal & Professional Fees	7,081.90	6,817.62	264.28	87,622.73	79,500.00	110.22%	(8,122.73)
Insurance Expense	1,580.99	1,463.21	117.78	18,972.56	17,500.00	108.41%	(1,472.56)
Community Programs & Donations	383.40	564.15	(180.75)	7,296.17	16,750.00	43.56%	9,453.83
Other Expenses	560.00	2,085.13	(1,525.13)	10,906.25	25,000.00	43.63%	14,093.75
Court Expense	0.00	25.11	(25.11)	158.00	300.00	52.67%	142.00
Repairs & Maintenance	3,012.84	4,639.82	(1,626.98)	43,981.40	65,501.66	67.15%	21,520.26
Interest Expense	0.00	83.37	(83.37)	97.88	1,000.00	9.79%	902.12
Capital	3,282.29	15,383.80	(12,101.51)	91,716.83	175,000.00	52.41%	83,283.17
Police Animal Control Expense	0.00	58.48	(58.48)	335.20	2,200.00	15.24%	1,864.80
Expense Totals	89,503.92	105,704.72	(16,200.80)	1,155,074.58	1,345,337.57	85.86%	190,262.99

City of Rice
 Financial Statement
 As of September 30, 2024

100 - General Fund	Current Month Actual	Current Month Budget	Budget Variance	YTD Actual	Annual Budget	% of Budget	Budget Remaining
Sales & Property Taxes							
100-4010 Ad Valorem Current	3,408.46	3,185.00	223.46	342,757.15	350,000.00	97.93%	7,242.85
100-4020 Ad Valorem Delinquent	4,789.86	250.00	4,539.86	9,718.11	5,000.00	194.36%	(4,718.11)
100-4130 Sales Tax Revenue	18,575.00	13,600.00	4,975.00	196,077.12	170,000.00	115.34%	(26,077.12)
100-4132 4B Economic Development Sales	0.00	3,750.00	(3,750.00)	0.00	45,000.00	0.00%	45,000.00
100-6572 Special General Fund Sales Tax	0.00	2,500.00	(2,500.00)	0.00	30,000.00	0.00%	30,000.00
Sales & Property Taxes Totals	26,773.32	23,285.00	3,488.32	548,552.38	600,000.00	91.43%	51,447.62
Interest Income							
100-4012 Ad Valorem Pent and Int	0.00	65.00	(65.00)	0.00	2,000.00	0.00%	2,000.00
100-4185 Interest Income	0.00	41.85	(41.85)	11.36	500.00	2.27%	488.64
Interest Income Totals	0.00	106.85	(106.85)	11.36	2,500.00	0.45%	2,488.64
Business & Franchise							
100-4140 Franchise Fee	922.27	834.00	88.27	64,166.66	60,000.00	106.94%	(4,166.66)
Business & Franchise Totals	922.27	834.00	88.27	64,166.66	60,000.00	106.94%	(4,166.66)
Leases & Rents							
100-4143 Communications Tower Rental	400.00	300.00	100.00	4,800.00	3,600.00	133.33%	(1,200.00)
100-4144 Office Lease - City Hall Annex	6,396.00	5,470.00	926.00	59,100.01	50,000.00	118.20%	(9,100.01)
100-4144 Office Lease - 20th Century Club	1,315.99	0.00	1,315.99	11,640.21	0.00	0.00%	(11,640.21)
Leases & Rents Totals	8,111.99	5,770.00	2,341.99	75,540.22	53,600.00	140.93%	(21,940.22)
Other Revenue Sources							
100-4190 Other Income	1,655.67	500.00	1,155.67	14,120.26	10,000.00	141.20%	(4,120.26)
100-4391 Prompt Pay State Fee Discount	0.00	0.00	0.00	4,041.36	12,000.00	33.68%	7,958.64
100-4902 Park Revenue	0.00	0.00	0.00	0.00	0.00	0.00%	0.00
100-4902 Park Revenue	424.09	837.00	(412.91)	17,371.46	10,000.00	173.71%	(7,371.46)

City of Rice
Financial Statement
As of September 30, 2024

100 - General Fund	Current Month Actual	Current Month Budget	Budget Variance	YTD Actual	Annual Budget	% of Budget	Budget Remaining
Other Revenue Sources							
100-4912 Recreation Center Rents & Fees	0.00	1,000.00	(1,000.00)	0.00	10,000.00	0.00%	10,000.00
Other Revenue Sources Totals	2,079.76	2,337.00	(257.24)	35,533.08	42,000.00	84.60%	6,466.92
Licenses & Permits							
100-4200 Permits and Licencing	2,786.49	2,400.00	386.49	16,710.21	30,000.00	55.70%	13,289.79
100-4202 Inspections	750.00	0.00	750.00	10,792.79	0.00	0.00%	(10,792.79)
Licenses & Permits Totals	3,536.49	2,400.00	1,136.49	27,503.00	30,000.00	91.68%	2,497.00
Fines & Fees							
100-4343 Special Expense Fee	8,731.92	4,000.00	4,731.92	75,297.13	50,000.00	150.59%	(25,297.13)
100-4353 6701d fines	25,740.75	19,251.00	6,489.75	290,759.12	230,000.00	126.42%	(60,759.12)
100-4363 Other Fines	2,146.50	2,000.00	146.50	27,723.32	25,000.00	110.89%	(2,723.32)
Fines & Fees Totals	36,619.17	25,251.00	11,368.17	393,779.57	305,000.00	129.11%	(88,779.57)
Court Revenues							
100-4373 Court Fees	4,729.28	2,560.00	2,169.28	43,662.56	32,000.00	136.45%	(11,662.56)
100-4383 Warrant Fees	2,781.67	1,750.00	1,031.67	25,195.22	25,000.00	100.78%	(195.22)
100-4385 Court Collections Revenue	1,732.34	1,255.50	476.84	17,205.65	15,000.00	114.70%	(2,205.65)
Court Revenues Totals	9,243.29	5,565.50	3,677.79	86,063.43	72,000.00	119.53%	(14,063.43)
Checking Account Carry Forward							
Year End Estimated Balance							
100-8000 Checking Account Carry Forward	0.00	16,740.00	(16,740.00)	0.00	200,000.00	0.00%	200,000.00
Checking Account Carry Forward Year End Estimated Balance Totals	0.00	16,740.00	(16,740.00)	0.00	200,000.00	0.00%	200,000.00
Revenue Totals	87,286.29	82,289.35	4,996.94	1,231,149.70	1,365,100.00	90.19%	133,950.30

City of Rice Financial Statement As of September 30, 2024

100 - General Fund General Administration	Current Month Actual	Current Month Budget	Budget Variance	YTD Actual	Annual Budget	% Budget Used	Budget Remaining
Community Programs & Donations	0.00	334.80	(334.80)	2,772.05	4,000.00	69.30%	1,227.95
Insurance Expense	212.67	209.25	3.42	2,551.98	2,500.00	102.08%	(51.98)
Legal & Professional Fees	2,350.00	1,815.27	534.73	16,290.88	21,400.00	76.13%	5,109.12
Office & Supplies	403.23	225.44	177.79	2,514.39	3,700.00	67.96%	1,185.61
Operating Expense	2,745.43	2,075.76	669.67	43,358.59	47,800.00	90.71%	4,441.41
Other Expenses	0.00	1,666.63	(1,666.63)	1,600.00	20,000.00	8.00%	18,400.00
Personnel/Payroll	12,429.79	13,132.66	(702.87)	159,797.29	165,044.00	96.82%	5,246.71
General Administration Totals	18,141.12	19,459.81	(1,318.69)	228,885.18	264,444.00	86.55%	35,558.82

100 - General Fund Municipal Court	Current Month Actual	Current Month Budget	Budget Variance	YTD Actual	Annual Budget	% Budget Used	Budget Remaining
Community Programs & Donations	0.00	62.50	(62.50)	0.00	750.00	0.00%	750.00
Court Expense	0.00	25.11	(25.11)	158.00	300.00	52.67%	142.00
Insurance Expense	10.92	83.70	(72.78)	131.04	1,000.00	13.10%	868.96
Legal & Professional Fees	2,351.14	2,176.20	174.94	24,750.61	26,000.00	95.19%	1,249.39
Office & Supplies	277.08	318.06	(40.98)	3,994.01	3,800.00	105.11%	(194.01)
Operating Expense	0.00	1,321.09	(1,321.09)	359.00	15,850.00	2.26%	15,491.00
Personnel/Payroll	8,628.50	8,342.52	285.98	111,159.93	106,644.13	104.23%	(4,515.80)
Municipal Court Totals	11,267.64	12,329.18	(1,061.54)	140,552.59	154,344.13	91.06%	13,791.54

100 - General Fund Municipal Buildings	Current Month Actual	Current Month Budget	Budget Variance	YTD Actual	Annual Budget	% Budget Used	Budget Remaining
Insurance Expense	374.56	334.80	39.76	4,494.72	4,000.00	112.37%	(494.72)
Legal & Professional Fees	0.00	292.95	(292.95)	4,002.85	3,500.00	114.37%	(502.85)
Office & Supplies	648.34	167.40	480.94	1,164.33	2,000.00	58.22%	835.67

City of Rice Financial Statement As of September 30, 2024

Operating Expense	4,939.25	3,636.70	1,302.55	51,633.84	45,000.00	114.74%	(6,633.84)
Repairs & Maintenance	410.27	167.40	242.87	7,736.69	12,000.00	64.47%	4,263.31
Municipal Buildings Totals	6,372.42	4,599.25	1,773.17	69,032.43	66,500.00	103.81%	(2,532.43)

100 - General Fund City Hall Annex	Current Month Actual	Current Month Budget	Budget Variance	YTD Actual	Annual Budget	% Budget Used	Budget Remaining
Legal & Professional Fees	0.00	50.00	(50.00)	0.00	600.00	0.00%	600.00
Operating Expense	340.50	602.20	(261.70)	3,400.53	7,200.00	47.23%	3,799.47
Repairs & Maintenance	0.00	1,160.77	(1,160.77)	5,691.70	10,901.66	52.21%	5,209.96
City Hall Annex Totals	340.50	1,812.97	(1,472.47)	9,092.23	18,701.66	48.62%	9,609.43

100 - General Fund Parks and Recreation	Current Month Actual	Current Month Budget	Budget Variance	YTD Actual	Annual Budget	% Budget Used	Budget Remaining
Capital	0.00	418.50	(418.50)	96.97	5,000.00	1.94%	4,903.03
Community Programs & Donations	383.40	0.00	383.40	4,376.64	10,000.00	43.77%	5,623.36
Insurance Expense	43.53	127.20	(83.67)	522.36	1,500.00	34.82%	977.64
Interest Expense	0.00	83.37	(83.37)	97.88	1,000.00	9.79%	902.12
Legal & Professional Fees	0.00	167.40	(167.40)	1,450.00	2,000.00	72.50%	550.00
Office & Supplies	0.00	108.48	(108.48)	427.48	6,950.00	6.15%	6,522.52
Operating Expense	493.40	2,038.30	(1,544.90)	13,220.63	15,250.00	86.69%	2,029.37
Other Expenses	560.00	418.50	141.50	9,306.25	5,000.00	186.13%	(4,306.25)
Personnel/Payroll	1,456.26	2,082.60	(626.34)	19,752.43	26,882.35	73.48%	7,129.92
Repairs & Maintenance	706.52	792.83	(86.31)	5,187.74	11,000.00	47.16%	5,812.26
Parks and Recreation Totals	3,643.11	6,237.18	(2,594.07)	54,438.38	84,582.35	64.36%	30,143.97

100 - General Fund Police	Current Month Actual	Current Month Budget	Budget Variance	YTD Actual	Annual Budget	% Budget Used	Budget Remaining
------------------------------	-------------------------	-------------------------	--------------------	---------------	------------------	------------------	---------------------

City of Rice Financial Statement As of September 30, 2024

	Current Month Actual	Current Month Budget	Budget Variance	YTD Actual	Annual Budget	% Budget Used	Budget Remaining
Capital	0.00	1,339.20	(1,339.20)	10,262.72	16,000.00	64.14%	5,737.28
Community Programs & Donations	0.00	41.85	(41.85)	147.48	500.00	29.50%	352.52
Insurance Expense	879.60	541.63	337.97	10,555.20	6,500.00	162.39%	(4,055.20)
Legal & Professional Fees	750.00	753.30	(3.30)	10,058.00	9,000.00	111.76%	(1,058.00)
Office & Supplies	565.82	1,573.56	(1,007.74)	16,420.30	18,800.00	87.34%	2,379.70
Operating Expense	220.09	702.53	(482.44)	9,780.13	8,400.00	116.43%	(1,380.13)
Personnel/Payroll	35,086.87	32,686.63	2,400.24	396,956.70	417,597.19	95.06%	20,640.49
Police Animal Control Expense	0.00	58.48	(58.48)	335.20	2,200.00	15.24%	1,864.80
Repairs & Maintenance	533.42	1,213.43	(680.01)	11,683.41	14,500.00	80.58%	2,816.59
Police Totals	38,035.80	38,910.61	(874.81)	466,199.14	493,497.19	94.47%	27,298.05

100 - General Fund Street	Current Month Actual	Current Month Budget	Budget Variance	YTD Actual	Annual Budget	% Budget Used	Budget Remaining
Capital	3,282.29	12,667.40	(9,385.11)	81,210.63	152,000.00	53.43%	70,789.37
Insurance Expense	59.71	166.63	(106.92)	717.26	2,000.00	35.86%	1,282.74
Legal & Professional Fees	0.00	0.00	0.00	88.46	0.00	0.00%	(88.46)
Office & Supplies	0.00	292.95	(292.95)	3,507.41	3,500.00	100.21%	(7.41)
Operating Expense	0.00	0.00	0.00	0.00	0.00	0.00%	0.00
Personnel/Payroll	5,367.94	5,201.78	166.16	56,327.82	65,618.24	85.84%	9,290.42
Repairs & Maintenance	1,362.63	1,305.39	57.24	13,681.86	17,100.00	80.01%	3,418.14
Street Totals	10,072.57	19,634.15	(9,561.58)	155,533.44	240,218.24	64.75%	84,684.80

100 - General Fund Community Support	Current Month Actual	Current Month Budget	Budget Variance	YTD Actual	Annual Budget	% Budget Used	Budget Remaining
Capital	0.00	958.70	(958.70)	146.51	2,000.00	7.33%	1,853.49
Community Programs & Donations	0.00	125.00	(125.00)	0.00	1,500.00	0.00%	1,500.00
Legal & Professional Fees	0.00	362.50	(362.50)	0.00	500.00	0.00%	500.00
Office & Supplies	0.00	4.24	(4.24)	17.99	450.00	4.00%	432.01

**City of Rice
Financial Statement
As of September 30, 2024**

Operating Expense	0.00	29.13	(29.13)	0.00	350.00	0.00%	350.00
Community Support Totals	0.00	1,479.57	(1,479.57)	164.50	4,800.00	3.43%	4,635.50

100 - General Fund Planning & Zoning	Current Month Actual	Current Month Budget	Budget Variance	YTD Actual	Annual Budget	% Budget Used	Budget Remaining
Legal & Professional Fees	1,630.76	1,200.00	430.76	30,981.93	16,500.00	187.77%	(14,481.93)
Office & Supplies	0.00	42.00	(42.00)	144.76	250.00	57.90%	105.24
Operating Expense	0.00	0.00	0.00	50.00	500.00	10.00%	450.00
Personnel/Payroll	0.00	0.00	0.00	0.00	1,000.00	0.00%	1,000.00
Planning & Zoning Totals	1,630.76	1,242.00	388.76	31,176.69	18,250.00	170.83%	(12,926.69)
Expense Total	89,503.92	105,704.72	(16,200.80)	1,155,074.58	1,345,337.57	85.86%	190,262.99

City of Rice Financial Statement As of September 30, 2024

100 - General Fund General Administration	Current Month Actual	Current Month Budget	Budget Variance	YTD Actual	Annual Budget	% Budget Used	Budget Remaining
100-10-5105 Director Salary	4,230.76	4,471.80	(241.04)	55,000.00	58,000.00	94.83%	3,000.00
100-10-5106 Clerical Wages	2,240.00	2,245.24	(5.24)	28,376.88	29,120.00	97.45%	743.12
100-10-5107 Operation Wages	0.00	0.00	0.00	0.00	0.00	0.00%	0.00
100-10-5108 Professional Salary	2,720.00	2,959.72	(239.72)	35,356.26	35,360.00	99.99%	3.74
100-10-5110 SS and Medicare	479.18	578.25	(99.07)	6,194.77	7,500.00	82.60%	1,305.23
100-10-5112 Unemployment - TWC	0.00	79.50	(79.50)	43.57	1,000.00	4.36%	956.43
100-10-5113 Retirement - TMRS	643.36	385.50	257.86	6,660.91	5,000.00	133.22%	(1,660.91)
100-10-5114 Worker Comp	189.87	231.30	(41.43)	2,496.54	3,000.00	83.22%	503.46
100-10-5115 Health Insurance	1,775.02	1,757.70	17.32	21,300.24	21,000.00	101.43%	(300.24)
100-10-5117 Life Insurance	89.60	47.22	42.38	1,075.20	564.00	190.64%	(511.20)
100-10-5201 Office Supplies	403.23	0.00	403.23	1,168.92	2,000.00	58.45%	831.08
100-10-5202 Printing Supplies	0.00	125.00	(125.00)	552.45	500.00	110.49%	(52.45)
100-10-5203 Postage	0.00	83.70	(83.70)	793.02	1,000.00	79.30%	206.98
100-10-5204 Office Equipment	814.90	0.00	814.90	1,299.88	1,500.00	86.66%	200.12
100-10-5205 Office Equipment Lease	910.84	502.20	408.64	5,675.38	6,000.00	94.59%	324.62
100-10-5206 Training Expense	0.00	334.80	(334.80)	3,021.02	4,000.00	75.53%	978.98
100-10-5207 Dues and Subscriptions	0.00	1,255.50	(1,255.50)	13,541.01	15,000.00	90.27%	1,458.99
100-10-5208 Credit Card Fees	0.00	100.44	(100.44)	0.00	1,200.00	0.00%	1,200.00
100-10-5209 Collection Expense	0.00	33.37	(33.37)	0.00	400.00	0.00%	400.00
100-10-5210 Telephone	0.00	0.00	0.00	0.00	0.00	0.00%	0.00
100-10-5215 Property and Liability	212.67	209.25	3.42	2,551.98	2,500.00	102.08%	(51.98)
100-10-5219 Professional Services	500.00	234.00	266.00	5,390.02	2,500.00	215.60%	(2,890.02)
100-10-5220 Election Expense	0.00	0.00	0.00	1,548.79	1,500.00	103.25%	(48.79)
100-10-5221 Property Tax Collection Fee	0.00	125.00	(125.00)	0.00	1,500.00	0.00%	1,500.00
100-10-5222 Navarro Appraisal District	0.00	0.00	0.00	8,643.25	5,000.00	172.87%	(3,643.25)
100-10-5223 Audit Expense	0.00	1,004.40	(1,004.40)	0.00	12,000.00	0.00%	12,000.00

City of Rice
 Financial Statement
 As of September 30, 2024

100 - General Fund General Administration	Current Month Actual	Current Month Budget	Budget Variance	YTD Actual	Annual Budget	% Budget Used	Budget Remaining
100-10-5224 Legal Fees	1,850.00	418.50	1,431.50	10,900.86	5,000.00	218.02%	(5,900.86)
100-10-5225 Bank Service Charges	40.00	8.37	31.63	80.83	100.00	80.83%	19.17
100-10-5227 Advertising	979.69	209.25	770.44	1,985.79	2,500.00	79.43%	514.21
100-10-5229 Public and Employee	0.00	334.80	(334.80)	2,772.05	4,000.00	69.30%	1,227.95
100-10-5415 Fuel	0.00	16.74	(16.74)	0.00	200.00	0.00%	200.00
100-10-5452 Hardware/Software	0.00	0.00	0.00	10,583.66	15,000.00	70.56%	4,416.34
100-10-5500 Uniform Expense	62.00	41.63	20.37	271.90	500.00	54.38%	228.10
100-10-5999 Miscellaneous Expense	0.00	0.00	0.00	0.00	0.00	0.00%	0.00
100-10-6573 Special General Fund Sales	0.00	1,666.63	(1,666.63)	1,600.00	20,000.00	8.00%	18,400.00
General Administration Totals	18,141.12	19,459.81	(1,318.69)	228,885.18	264,444.00	86.55%	35,558.82

City of Rice
 Financial Statement
 As of September 30, 2024

100 - General Fund Municipal Court	Current Month Actual	Current Month Budget	Budget Variance	YTD Actual	Annual Budget	% Budget Used	Budget Remaining
100-20-5105 Director Salary	4,000.00	4,009.20	(9.20)	52,000.00	52,000.00	100.00%	0.00
100-20-5106 Clerical Wages	1,927.50	1,924.46	3.04	25,192.50	24,960.00	100.93%	(232.50)
100-20-5108 Professional Salary	800.00	800.00	0.00	9,600.00	9,600.00	100.00%	0.00
100-20-5110 SS and Medicare	448.58	422.91	25.67	5,845.23	4,460.13	131.06%	(1,385.10)
100-20-5112 Unemployment - TWC	0.00	28.50	(28.50)	46.04	342.00	13.46%	295.96
100-20-5113 Retirement - TMRS	414.93	154.20	260.73	4,418.47	2,000.00	220.92%	(2,418.47)
100-20-5114 Worker Comp	126.58	59.60	66.98	1,664.34	2,000.00	83.22%	335.66
100-20-5115 Health Insurance	906.91	795.15	111.76	10,882.92	9,500.00	114.56%	(1,382.92)
100-20-5117 Life Insurance	4.00	23.50	(19.50)	48.00	282.00	17.02%	234.00
100-20-5201 Office Supplies	0.00	41.85	(41.85)	490.21	500.00	98.04%	9.79
100-20-5202 Printing Supplies	0.00	125.55	(125.55)	978.10	1,500.00	65.21%	521.90
100-20-5203 Postage	277.08	150.66	126.42	2,525.70	1,800.00	140.32%	(725.70)
100-20-5204 Office Equipment	0.00	50.22	(50.22)	249.00	600.00	41.50%	351.00
100-20-5205 Office Equipment Lease	0.00	0.00	0.00	0.00	0.00	0.00%	0.00
100-20-5206 Training Expense	0.00	125.00	(125.00)	1,462.43	1,500.00	97.50%	37.57
100-20-5207 Dues and Subscriptions	0.00	20.87	(20.87)	110.00	250.00	44.00%	140.00
100-20-5208 Credit Card Fees	0.00	1,250.00	(1,250.00)	0.00	15,000.00	0.00%	15,000.00
100-20-5209 Collection Expense	640.17	1,674.00	(1,033.83)	15,520.97	20,000.00	77.60%	4,479.03
100-20-5215 Property and Liability	10.92	83.70	(72.78)	131.04	1,000.00	13.10%	868.96
100-20-5219 Professional Services	1,710.97	502.20	1,208.77	9,229.64	6,000.00	153.83%	(3,229.64)
100-20-5229 Public and Employee	0.00	62.50	(62.50)	0.00	750.00	0.00%	750.00
100-20-5300 Jury Expense	0.00	25.11	(25.11)	158.00	300.00	52.67%	142.00
100-20-5452 Hardware/Software	0.00	0.00	0.00	0.00	0.00	0.00%	0.00
Municipal Court Totals	11,267.64	12,329.18	(1,061.54)	140,552.59	154,344.13	91.06%	13,791.54

City of Rice
 Financial Statement
 As of September 30, 2024

100 - General Fund Municipal Buildings	Current Month Actual	Current Month Budget	Budget Variance	YTD Actual	Annual Budget	% Budget Used	Budget Remaining
100-30-5210 Telephone	421.18	460.35	(39.17)	5,046.84	5,500.00	91.76%	453.16
100-30-5211 Electric Service	10.47	0.00	10.47	534.41	0.00	0.00%	(534.41)
100-30-5211 Electric Service - buildings,	3,066.69	2,511.00	555.69	31,581.00	30,000.00	105.27%	(1,581.00)
100-30-5212 Gas Service - 20th Century	0.00	0.00	0.00	171.66	0.00	0.00%	(171.66)
100-30-5212 Gas Service	329.90	335.50	(5.60)	5,283.94	5,000.00	105.68%	(283.94)
100-30-5213 Water Service - 20th	399.72	119.85	279.87	3,636.70	1,500.00	242.45%	(2,136.70)
100-30-5213 Water Service	711.29	210.00	501.29	5,379.29	3,000.00	179.31%	(2,379.29)
100-30-5215 Property and Liability	374.56	334.80	39.76	4,494.72	4,000.00	112.37%	(494.72)
100-30-5219 Professional Services	0.00	292.95	(292.95)	4,002.85	3,500.00	114.37%	(502.85)
100-30-5230 Building Repairs	410.27	0.00	410.27	5,946.59	10,000.00	59.47%	4,053.41
100-30-5230 Building Repairs	0.00	0.00	0.00	818.49	0.00	0.00%	(818.49)
100-30-5405 Maintenance Supplies	0.00	83.70	(83.70)	917.97	1,000.00	91.80%	82.03
100-30-5420 Cleaning and Janitorial	648.34	167.40	480.94	1,164.33	2,000.00	58.22%	835.67
100-30-5450 Tools / Equipment	0.00	83.70	(83.70)	53.64	1,000.00	5.36%	946.36
Municipal Buildings Totals	6,372.42	4,599.25	1,773.17	69,032.43	66,500.00	103.81%	(2,532.43)

City of Rice
 Financial Statement
 As of September 30, 2024

100 - General Fund City Hall Annex	Current Month Actual	Current Month Budget	Budget Variance	YTD Actual	Annual Budget	% Budget Used	Budget Remaining
100-32-5211 Electric Service - 205 E	340.50	418.50	(78.00)	3,164.14	5,000.00	63.28%	1,835.86
100-32-5212 Gas Service	0.00	100.00	(100.00)	0.00	1,200.00	0.00%	1,200.00
100-32-5213 Water Service - 20th	0.00	0.00	0.00	200.77	0.00	0.00%	(200.77)
100-32-5213 Water Service - Annex	0.00	0.00	0.00	35.62	0.00	0.00%	(35.62)
100-32-5219 Professional Services -	0.00	50.00	(50.00)	0.00	600.00	0.00%	600.00
100-32-5227 Advertising	0.00	83.70	(83.70)	0.00	1,000.00	0.00%	1,000.00
100-32-5230 Building Repairs - Annex	0.00	418.50	(418.50)	153.77	5,000.00	3.08%	4,846.23
100-32-5230 Building Repairs - 20th	0.00	600.00	(600.00)	5,000.00	5,000.00	100.00%	0.00
100-32-5405 Maintenance Supplies	0.00	41.85	(41.85)	119.28	500.00	23.86%	380.72
100-32-5426 Insurance Claim	0.00	100.42	(100.42)	418.65	401.66	104.23%	(16.99)
City Hall Annex Totals	340.50	1,812.97	(1,472.47)	9,092.23	18,701.66	48.62%	9,609.43

City of Rice
 Financial Statement
 As of September 30, 2024

100 - General Fund Parks and Recreation	Current Month Actual	Current Month Budget	Budget Variance	YTD Actual	Annual Budget	% Budget Used	Budget Remaining
100-40-5106 Clerical Wages	0.00	0.00	0.00	0.00	0.00	0.00%	0.00
100-40-5107 Operation Wages	1,043.16	1,563.61	(520.45)	14,275.08	20,280.00	70.39%	6,004.92
100-40-5110 SS and Medicare	276.79	251.10	25.69	3,667.63	3,000.00	122.25%	(667.63)
100-40-5112 Unemployment - TWC	0.00	20.98	(20.98)	87.13	250.00	34.85%	162.87
100-40-5113 Retirement - TMRS	73.02	38.55	34.47	890.42	500.00	178.08%	(390.42)
100-40-5114 Worker Comp	63.29	208.36	(145.07)	832.17	2,702.35	30.79%	1,870.18
100-40-5211 Electric Service	168.19	753.30	(585.11)	8,079.35	9,000.00	89.77%	920.65
100-40-5213 Water Service	325.21	225.00	100.21	1,078.29	1,500.00	71.89%	421.71
100-40-5215 Property and Liability	43.53	127.20	(83.67)	522.36	1,500.00	34.82%	977.64
100-40-5219 Professional Services	0.00	167.40	(167.40)	1,450.00	2,000.00	72.50%	550.00
100-40-5226 Credit Card Interest and	0.00	83.37	(83.37)	97.88	1,000.00	9.79%	902.12
100-40-5227 Advertising	0.00	0.00	0.00	75.00	750.00	10.00%	675.00
100-40-5229 Public and Employee	383.40	0.00	383.40	4,376.64	10,000.00	43.77%	5,623.36
100-40-5230 Building Repairs	0.00	0.00	0.00	2,970.00	5,000.00	59.40%	2,030.00
100-40-5400 Gravel and Asphalt	0.00	500.00	(500.00)	600.00	500.00	120.00%	(100.00)
100-40-5401 Concession Products and	0.00	0.00	0.00	0.00	500.00	0.00%	500.00
100-40-5402 Recreational Supplies	0.00	0.00	0.00	283.52	5,000.00	5.67%	4,716.48
100-40-5405 Maintenance Supplies	0.00	83.70	(83.70)	155.04	1,000.00	15.50%	844.96
100-40-5406 Chemical Supplies	0.00	41.85	(41.85)	194.84	500.00	38.97%	305.16
100-40-5407 General Safety Supplies	0.00	25.11	(25.11)	24.36	300.00	8.12%	275.64
100-40-5408 Protective Clothing	0.00	0.00	0.00	0.00	150.00	0.00%	150.00
100-40-5415 Fuel	0.00	83.37	(83.37)	0.00	1,000.00	0.00%	1,000.00
100-40-5420 Cleaning and Janitorial	0.00	0.00	0.00	119.60	150.00	79.73%	30.40
100-40-5450 Tools / Equipment	193.99	41.63	152.36	193.99	500.00	38.80%	306.01
100-40-5452 Hardware/Software	0.00	1,060.00	(1,060.00)	3,987.99	4,000.00	99.70%	12.01
100-40-5502 Building and Grounds -	350.00	0.10	349.90	911.34	1,000.00	91.13%	88.66

**City of Rice
Financial Statement
As of September 30, 2024**

100 - General Fund Parks and Recreation	Current Month Actual	Current Month Budget	Budget Variance	YTD Actual	Annual Budget	% Budget Used	Budget Remaining
100-40-5504 Parking Lot - Maintenance	0.00	125.55	(125.55)	0.00	1,500.00	0.00%	1,500.00
100-40-5508 Ball Field - Maintenance	162.53	0.00	162.53	162.53	1,000.00	16.25%	837.47
100-40-5610 Outside Contracts	560.00	418.50	141.50	9,306.25	5,000.00	186.13%	(4,306.25)
100-40-6008 Playground Equipment	0.00	418.50	(418.50)	96.97	5,000.00	1.94%	4,903.03
Parks and Recreation Totals	3,643.11	6,237.18	(2,594.07)	54,438.38	84,582.35	64.36%	30,143.97

City of Rice
 Financial Statement
 As of September 30, 2024

100 - General Fund Police	Current Month Actual	Current Month Budget	Budget Variance	YTD Actual	Annual Budget	% Budget Used	Budget Remaining
100-50-5105 Director Salary	4,615.38	4,626.00	(10.62)	60,000.00	60,000.00	100.00%	0.00
100-50-5106 Clerical Wages	3,158.79	2,726.30	432.49	36,844.10	35,360.00	104.20%	(1,484.10)
100-50-5107 Operation Wages	16,596.41	15,805.50	790.91	191,093.14	205,000.00	93.22%	13,906.86
100-50-5110 SS and Medicare	1,850.43	1,779.06	71.37	21,756.66	21,255.00	102.36%	(501.66)
100-50-5112 Unemployment - TWC	11.75	99.75	(88.00)	243.55	1,197.00	20.35%	953.45
100-50-5113 Retirement - TMRS	1,712.94	1,340.99	371.95	16,035.07	17,393.19	92.19%	1,358.12
100-50-5114 Worker Comp	379.74	669.60	(289.86)	4,993.02	8,000.00	62.41%	3,006.98
100-50-5115 Health Insurance	5,402.63	5,022.00	380.63	60,838.07	60,000.00	101.40%	(838.07)
100-50-5117 Life Insurance	58.80	141.00	(82.20)	640.30	1,692.00	37.84%	1,051.70
100-50-5118 Cell Phone Allowance	100.00	100.00	0.00	1,200.00	1,200.00	100.00%	0.00
100-50-5201 Office Supplies	65.88	66.96	(1.08)	422.37	800.00	52.80%	377.63
100-50-5202 Printing Supplies	271.78	83.70	188.08	329.73	1,000.00	32.97%	670.27
100-50-5203 Postage	62.40	83.70	(21.30)	706.88	1,000.00	70.69%	293.12
100-50-5204 Office Equipment	0.00	0.00	0.00	176.69	0.00	0.00%	(176.69)
100-50-5205 Office Equipment Lease	107.21	125.55	(18.34)	1,476.30	1,500.00	98.42%	23.70
100-50-5206 Training Expense	0.00	0.00	0.00	0.00	2,000.00	0.00%	2,000.00
100-50-5210 Telephone	112.88	116.63	(3.75)	883.84	1,400.00	63.13%	516.16
100-50-5215 Property and Liability	879.60	541.63	337.97	10,555.20	6,500.00	162.39%	(4,055.20)
100-50-5219 Professional Services	750.00	753.30	(3.30)	10,058.00	9,000.00	111.76%	(1,058.00)
100-50-5227 Advertising	0.00	8.37	(8.37)	0.00	100.00	0.00%	100.00
100-50-5229 Public and Employee	0.00	41.85	(41.85)	147.48	500.00	29.50%	352.52
100-50-5230 Building Repairs	0.00	251.10	(251.10)	2,000.00	3,000.00	66.67%	1,000.00
100-50-5231 Laboratory Supplies	92.00	83.70	8.30	1,027.20	1,000.00	102.72%	(27.20)
100-50-5408 Protective Clothing	1,200.00	125.55	1,074.45	1,200.00	1,500.00	80.00%	300.00
100-50-5409 Ammunition Expense	0.00	83.70	(83.70)	883.98	1,000.00	88.40%	116.02
100-50-5411 Protective Equipment	0.00	41.63	(41.63)	423.00	500.00	84.60%	77.00

City of Rice
 Financial Statement
 As of September 30, 2024

100 - General Fund Police	Current Month Actual	Current Month Budget	Budget Variance	YTD Actual	Annual Budget	% Budget Used	Budget Remaining
100-50-5415 Fuel	73.76	1,255.50	(1,181.74)	13,934.12	15,000.00	92.89%	1,065.88
100-50-5424 Vehicle Maintenance	202.94	334.80	(131.86)	3,900.51	4,000.00	97.51%	99.49
100-50-5425 Automobile Repair Expense	49.50	418.50	(369.00)	4,584.41	5,000.00	91.69%	415.59
100-50-5426 Insurance Claim	0.00	0.00	0.00	(649.00)	0.00	0.00%	649.00
100-50-5450 Tools / Equipment	280.98	167.40	113.58	1,847.49	2,000.00	92.37%	152.51
100-50-5452 Hardware/Software	0.00	451.98	(451.98)	7,243.30	5,400.00	134.14%	(1,843.30)
100-50-5500 Uniform Expense	0.00	125.55	(125.55)	805.81	1,500.00	53.72%	694.19
100-50-5550 Animal Control - Food	0.00	16.63	(16.63)	95.20	200.00	47.60%	104.80
100-50-5551 Animal Control - Cages	0.00	0.00	0.00	80.00	1,500.00	5.33%	1,420.00
100-50-5552 Animal Control - Pound Fees	0.00	41.85	(41.85)	160.00	500.00	32.00%	340.00
100-50-5600 Communications Tower	0.00	41.63	(41.63)	0.00	500.00	0.00%	500.00
100-50-6003 C. O. - Vehicles	0.00	1,339.20	(1,339.20)	10,262.72	16,000.00	64.14%	5,737.28
Police Totals	38,035.80	38,910.61	(874.81)	466,199.14	493,497.19	94.47%	27,298.05

City of Rice Financial Statement As of September 30, 2024

100 - General Fund Street	Current Month Actual	Current Month Budget	Budget Variance	YTD Actual	Annual Budget	% Budget Used	Budget Remaining
100-60-5104 Part Time Wages	0.00	833.37	(833.37)	1,269.00	10,000.00	12.69%	8,731.00
100-60-5107 Operation Wages	3,728.00	2,726.30	1,001.70	37,071.00	35,360.00	104.84%	(1,711.00)
100-60-5109 Contract Labor	0.00	125.55	(125.55)	338.28	1,500.00	22.55%	1,161.72
100-60-5110 SS and Medicare	277.18	292.95	(15.77)	2,804.84	3,500.00	80.14%	695.16
100-60-5112 Unemployment - TWC	13.10	16.74	(3.64)	31.94	200.00	15.97%	168.06
100-60-5113 Retirement - TMRS	144.28	185.82	(41.54)	2,025.32	2,220.05	91.23%	194.73
100-60-5114 Worker Comp	126.58	226.14	(99.56)	1,591.37	2,702.35	58.89%	1,110.98
100-60-5115 Health Insurance	887.51	736.32	151.19	10,650.12	8,835.84	120.53%	(1,814.28)
100-60-5117 Life Insurance	23.40	41.85	(18.45)	280.80	500.00	56.16%	219.20
100-60-5206 Training Expense	0.00	16.74	(16.74)	0.00	200.00	0.00%	200.00
100-60-5215 Property and Liability	59.71	166.63	(106.92)	717.26	2,000.00	35.86%	1,282.74
100-60-5219 Professional Services	0.00	0.00	0.00	88.46	0.00	0.00%	(88.46)
100-60-5227 Advertising	0.00	0.00	0.00	0.00	0.00	0.00%	0.00
100-60-5400 Gravel and Asphalt	0.00	837.00	(837.00)	9,407.27	10,000.00	94.07%	592.73
100-60-5403 Street Sign Maintenance	1,043.01	125.55	917.46	1,043.01	1,500.00	69.53%	456.99
100-60-5405 Maintenance Supplies	0.00	41.85	(41.85)	96.12	500.00	19.22%	403.88
100-60-5406 Chemical Supplies	0.00	25.11	(25.11)	179.56	300.00	59.85%	120.44
100-60-5407 General Safety Supplies	0.00	0.00	0.00	12.95	0.00	0.00%	(12.95)
100-60-5408 Protective Clothing	0.00	0.00	0.00	0.00	100.00	0.00%	100.00
100-60-5410 Diesel Fuel	0.00	25.00	(25.00)	0.00	300.00	0.00%	300.00
100-60-5415 Fuel	0.00	292.95	(292.95)	3,494.46	3,500.00	99.84%	5.54
100-60-5424 Vehicle Maintenance	0.00	83.70	(83.70)	33.50	1,000.00	3.35%	966.50
100-60-5425 Automobile Repair Expense	0.00	41.63	(41.63)	187.12	500.00	37.42%	312.88
100-60-5427 Equipment Repairs	0.00	125.55	(125.55)	1,524.60	1,500.00	101.64%	(24.60)
100-60-5450 Tools / Equipment	319.62	0.00	319.62	1,210.68	1,500.00	80.71%	289.32
100-60-5500 Uniform Expense	167.89	0.00	167.89	265.15	500.00	53.03%	234.85

City of Rice
 Financial Statement
 As of September 30, 2024

100 - General Fund Street	Current Month Actual	Current Month Budget	Budget Variance	YTD Actual	Annual Budget	% Budget Used	Budget Remaining
100-60-6004 C. O. - Equipment	1,482.29	167.40	1,314.89	1,782.29	2,000.00	89.11%	217.71
100-60-6006 C.O. - Street Improvements	1,800.00	12,500.00	(10,700.00)	79,428.34	150,000.00	52.95%	70,571.66
Street Totals	10,072.57	19,634.15	(9,561.58)	155,533.44	240,218.24	64.75%	84,684.80

City of Rice
 Financial Statement
 As of September 30, 2024

100 - General Fund Community Support	Current Month Actual	Current Month Budget	Budget Variance	YTD Actual	Annual Budget	% Budget Used	Budget Remaining
100-70-5201 Office Supplies	0.00	4.24	(4.24)	17.99	50.00	35.98%	32.01
100-70-5202 Printing Supplies	0.00	0.00	0.00	0.00	250.00	0.00%	250.00
100-70-5203 Postage	0.00	0.00	0.00	0.00	150.00	0.00%	150.00
100-70-5219 Professional Services	0.00	362.50	(362.50)	0.00	500.00	0.00%	500.00
100-70-5227 Advertising	0.00	29.13	(29.13)	0.00	350.00	0.00%	350.00
100-70-5229 Public and Employee	0.00	125.00	(125.00)	0.00	1,500.00	0.00%	1,500.00
100-70-6004 C. O. - Equipment	0.00	83.70	(83.70)	0.00	1,000.00	0.00%	1,000.00
100-70-6005 C. O. - Hardware/Software	0.00	875.00	(875.00)	146.51	1,000.00	14.65%	853.49
Community Support Totals	0.00	1,479.57	(1,479.57)	164.50	4,800.00	3.43%	4,635.50

City of Rice
 Financial Statement
 As of September 30, 2024

100 - General Fund Planning & Zoning	Current Month Actual	Current Month Budget	Budget Variance	YTD Actual	Annual Budget	% Budget Used	Budget Remaining
100-72-5203 Postage	0.00	42.00	(42.00)	144.76	250.00	57.90%	105.24
100-72-5206 Training Expense	0.00	0.00	0.00	0.00	1,000.00	0.00%	1,000.00
100-72-5207 Dues and Subscriptions	0.00	0.00	0.00	0.00	250.00	0.00%	250.00
100-72-5219 Professional Services	1,630.76	1,200.00	430.76	30,981.93	15,000.00	206.55%	(15,981.93)
100-72-5224 Legal Fees	0.00	0.00	0.00	0.00	1,500.00	0.00%	1,500.00
100-72-5227 Advertising	0.00	0.00	0.00	50.00	250.00	20.00%	200.00
Planning & Zoning Totals	1,630.76	1,242.00	388.76	31,176.69	18,250.00	170.83%	(12,926.69)
Expense Totals	89,503.92	105,704.72	(16,200.80)	1,155,074.58	1,345,337.57	85.86%	190,262.99

City of Rice
Financial Statement
As of September 30, 2024

202 - Court Technology Fund	Current Month Actual	Current Month Budget	Budget Variance	YTD Actual	Annual Budget	% of Budget	Budget Remaining
Revenue Summary							
Other Revenue Sources	1,023.01	669.60	353.41	10,257.77	8,000.00	128.22%	(2,257.77)
Revenue Totals	<u>1,023.01</u>	<u>669.60</u>	<u>353.41</u>	<u>10,257.77</u>	<u>8,000.00</u>	<u>128.22%</u>	<u>(2,257.77)</u>
Expense Summary							
Court Expense	15.99	0.00	15.99	9,844.37	8,000.00	123.05%	(1,844.37)
Expense Totals	<u>15.99</u>	<u>0.00</u>	<u>15.99</u>	<u>9,844.37</u>	<u>8,000.00</u>	<u>123.05%</u>	<u>(1,844.37)</u>

**City of Rice
 Financial Statement
 As of September 30, 2024**

202 - Court Technology Fund	Current Month Actual	Current Month Budget	Budget Variance	YTD Actual	Annual Budget	% of Budget	Budget Remaining
Other Revenue Sources							
202-4701 Technology Fee	1,023.01	669.60	353.41	10,257.77	8,000.00	128.22%	(2,257.77)
Other Revenue Sources Totals	1,023.01	669.60	353.41	10,257.77	8,000.00	128.22%	(2,257.77)
Revenue Totals	1,023.01	669.60	353.41	10,257.77	8,000.00	128.22%	(2,257.77)

City of Rice
 Financial Statement
 As of September 30, 2024

202 - Court Technology Fund Municipal Court	Current Month Actual	Current Month Budget	Budget Variance	YTD Actual	Annual Budget	% Budget Used	Budget Remaining
Court Expense	15.99	0.00	15.99	9,844.37	8,000.00	123.05%	(1,844.37)
Municipal Court Totals	15.99	0.00	15.99	9,844.37	8,000.00	123.05%	(1,844.37)
Expense Total	15.99	0.00	15.99	9,844.37	8,000.00	123.05%	(1,844.37)

**City of Rice
 Financial Statement
 As of September 30, 2024**

202 - Court Technology Fund Municipal Court	Current Month Actual	Current Month Budget	Budget Variance	YTD Actual	Annual Budget	% Budget Used	Budget Remaining
202-20-5320 Court Technology	15.99	0.00	15.99	9,844.37	8,000.00	123.05%	(1,844.37)
Municipal Court Totals	15.99	0.00	15.99	9,844.37	8,000.00	123.05%	(1,844.37)
Expense Totals	15.99	0.00	15.99	9,844.37	8,000.00	123.05%	(1,844.37)

City of Rice
Financial Statement
As of September 30, 2024

203 - Court Security Fund	Current Month Actual	Current Month Budget	Budget Variance	YTD Actual	Annual Budget	% of Budget	Budget Remaining
Revenue Summary							
Other Revenue Sources	1,212.73	696.00	516.73	12,138.63	8,000.00	151.73%	(4,138.63)
Revenue Totals	<u>1,212.73</u>	<u>696.00</u>	<u>516.73</u>	<u>12,138.63</u>	<u>8,000.00</u>	<u>151.73%</u>	<u>(4,138.63)</u>
Expense Summary							
Court Expense	0.00	0.00	0.00	0.00	6,000.00	0.00%	6,000.00
Expense Totals	<u>0.00</u>	<u>0.00</u>	<u>0.00</u>	<u>0.00</u>	<u>6,000.00</u>	<u>0.00%</u>	<u>6,000.00</u>

City of Rice
 Financial Statement
 As of September 30, 2024

203 - Court Security Fund	Current Month Actual	Current Month Budget	Budget Variance	YTD Actual	Annual Budget	% of Budget	Budget Remaining
Other Revenue Sources							
203-4703 Security	1,212.73	696.00	516.73	12,138.63	8,000.00	151.73%	(4,138.63)
Other Revenue Sources Totals	1,212.73	696.00	516.73	12,138.63	8,000.00	151.73%	(4,138.63)
Revenue Totals	1,212.73	696.00	516.73	12,138.63	8,000.00	151.73%	(4,138.63)

**City of Rice
 Financial Statement
 As of September 30, 2024**

203 - Court Security Fund Municipal Court	Current Month Actual	Current Month Budget	Budget Variance	YTD Actual	Annual Budget	% Budget Used	Budget Remaining
Court Expense	0.00	0.00	0.00	0.00	6,000.00	0.00%	6,000.00
Municipal Court Totals	0.00	0.00	0.00	0.00	6,000.00	0.00%	6,000.00
Expense Total	0.00	0.00	0.00	0.00	6,000.00	0.00%	6,000.00

**City of Rice
 Financial Statement
 As of September 30, 2024**

203 - Court Security Fund Municipal Court	Current Month Actual	Current Month Budget	Budget Variance	YTD Actual	Annual Budget	% Budget Used	Budget Remaining
203-20-5310 Court Security	0.00	0.00	0.00	0.00	6,000.00	0.00%	6,000.00
Municipal Court Totals	0.00	0.00	0.00	0.00	6,000.00	0.00%	6,000.00
Expense Totals	0.00	0.00	0.00	0.00	6,000.00	0.00%	6,000.00

**City of Rice
Financial Statement
As of September 30, 2024**

204 - Court Fines/Local Truancy & Prevention Diversion Fund	Current Month Actual	Current Month Budget	Budget Variance	YTD Actual	Annual Budget	% of Budget	Budget Remaining
Revenue Summary							
Court Revenues	1,172.23	420.00	752.23	11,697.92	6,000.00	194.97%	(5,697.92)
Revenue Totals	1,172.23	420.00	752.23	11,697.92	6,000.00	194.97%	(5,697.92)
Expense Summary							
Court Expense	0.00	500.00	(500.00)	0.00	6,000.00	0.00%	6,000.00
Expense Totals	0.00	500.00	(500.00)	0.00	6,000.00	0.00%	6,000.00

**City of Rice
 Financial Statement
 As of September 30, 2024**

204 - Court Fines/Local Truancy & Prevention Diversion Fund	Current Month Actual	Current Month Budget	Budget Variance	YTD Actual	Annual Budget	% of Budget	Budget Remaining
Court Revenues							
204-4373 Court Fees	1,172.23	420.00	752.23	11,697.92	6,000.00	194.97%	(5,697.92)
Court Revenues Totals	1,172.23	420.00	752.23	11,697.92	6,000.00	194.97%	(5,697.92)
Revenue Totals	1,172.23	420.00	752.23	11,697.92	6,000.00	194.97%	(5,697.92)

**City of Rice
 Financial Statement
 As of September 30, 2024**

204 - Court Fines/Local Truancy & Pre Truancy & Prevention Diversion	Current Month Actual	Current Month Budget	Budget Variance	YTD Actual	Annual Budget	% Budget Used	Budget Remaining
Court Expense	0.00	500.00	(500.00)	0.00	6,000.00	0.00%	6,000.00
Truancy & Prevention Diversion Fund	0.00	500.00	(500.00)	0.00	6,000.00	0.00%	6,000.00
Expense Total	0.00	500.00	(500.00)	0.00	6,000.00	0.00%	6,000.00

City of Rice
 Financial Statement
 As of September 30, 2024

204 - Court Fines/Local Truancy & Pre Truancy & Prevention Diversion	Current Month Actual	Current Month Budget	Budget Variance	YTD Actual	Annual Budget	% Budget Used	Budget Remaining
204-20-4374 Truancy & Prevention	0.00	500.00	(500.00)	0.00	6,000.00	0.00%	6,000.00
Truancy & Prevention Diversion Fund T	0.00	500.00	(500.00)	0.00	6,000.00	0.00%	6,000.00
Expense Totals	0.00	500.00	(500.00)	0.00	6,000.00	0.00%	6,000.00

City of Rice
 Financial Statement
 As of September 30, 2024

205 - Court Fines/Municipal Jury Fund		Current Month Actual	Current Month Budget	Budget Variance	YTD Actual	Annual Budget	% of Budget	Budget Remaining
Revenue Summary								
Court Revenues		396.44	160.00	236.44	3,957.93	2,000.00	197.90%	(1,957.93)
Revenue Totals		396.44	160.00	236.44	3,957.93	2,000.00	197.90%	(1,957.93)
Expense Summary								
Court Expense		0.00	166.63	(166.63)	0.00	2,000.00	0.00%	2,000.00
Expense Totals		0.00	166.63	(166.63)	0.00	2,000.00	0.00%	2,000.00

City of Rice
 Financial Statement
 As of September 30, 2024

205 - Court Fines/Municipal Jury Fund		Current Month Actual	Current Month Budget	Budget Variance	YTD Actual	Annual Budget	% of Budget	Budget Remaining
Court Revenues								
205-4373 Court Fees		396.44	160.00	236.44	3,957.93	2,000.00	197.90%	(1,957.93)
Court Revenues Totals		396.44	160.00	236.44	3,957.93	2,000.00	197.90%	(1,957.93)
Revenue Totals		396.44	160.00	236.44	3,957.93	2,000.00	197.90%	(1,957.93)

City of Rice
 Financial Statement
 As of September 30, 2024

205 - Court Fines/Municipal Jury Fund Jury Expense	Current Month Actual	Current Month Budget	Budget Variance	YTD Actual	Annual Budget	% Budget Used	Budget Remaining
Court Expense	0.00	166.63	(166.63)	0.00	2,000.00	0.00%	2,000.00
Jury Expense Totals	0.00	166.63	(166.63)	0.00	2,000.00	0.00%	2,000.00
Expense Total	0.00	166.63	(166.63)	0.00	2,000.00	0.00%	2,000.00

City of Rice
 Financial Statement
 As of September 30, 2024

205 - Court Fines/Municipal Jury Fund Jury Expense	Current Month Actual	Current Month Budget	Budget Variance	YTD Actual	Annual Budget	% Budget Used	Budget Remaining
205-20-5300 Jury Expense	0.00	166.63	(166.63)	0.00	2,000.00	0.00%	2,000.00
Jury Expense Totals	0.00	166.63	(166.63)	0.00	2,000.00	0.00%	2,000.00
Expense Totals	0.00	166.63	(166.63)	0.00	2,000.00	0.00%	2,000.00

**City of Rice
 Financial Statement
 As of September 30, 2024**

	Current Month Actual	Current Month Budget	Budget Variance	YTD Actual	Annual Budget	% of Budget	Budget Remaining
Revenue Summary							
Court Reserves Carry Forward Year End	0.00	5,764.13	(5,764.13)	0.00	69,170.00	0.00%	69,170.00
Transfers In	0.00	0.00	0.00	94,070.19	0.00	0.00%	(94,070.19)
Revenue Totals	0.00	5,764.13	(5,764.13)	94,070.19	69,170.00	136.00%	(24,900.19)
Expense Summary							
Court Reserves Carry Forward Year End	0.00	5,764.13	(5,764.13)	0.00	69,170.00	0.00%	69,170.00
Expense Totals	0.00	5,764.13	(5,764.13)	0.00	69,170.00	0.00%	69,170.00

City of Rice
 Financial Statement
 As of September 30, 2024

	Current Month Actual	Current Month Budget	Budget Variance	YTD Actual	Annual Budget	% of Budget	Budget Remaining
Court Reserves Carry Forward Year End Balance- Technology, Security, Jury, Truancy							
207-4377 Court Reserves Carry Forward	0.00	5,764.13	(5,764.13)	0.00	69,170.00	0.00%	69,170.00
Court Reserves Carry Forward Year End Balance- Technology, Security, Jury, Truancy Totals	0.00	5,764.13	(5,764.13)	0.00	69,170.00	0.00%	69,170.00
Transfers In							
207-4999 Transfers In	0.00	0.00	0.00	94,070.19	0.00	0.00%	(94,070.19)
Transfers In Totals	0.00	0.00	0.00	94,070.19	0.00	0.00%	(94,070.19)
Revenue Totals	0.00	5,764.13	(5,764.13)	94,070.19	69,170.00	136.00%	(24,900.19)

**City of Rice
Financial Statement
As of September 30, 2024**

207 - Court Reserves Carry Forward Y Court Reserves Carry Forward Y	Current Month Actual	Current Month Budget	Budget Variance	YTD Actual	Annual Budget	% Budget Used	Budget Remaining
Court Reserves Carry Forward Year End	0.00	5,764.13	(5,764.13)	0.00	69,170.00	0.00%	69,170.00
Court Reserves Carry Forward Year En	0.00	5,764.13	(5,764.13)	0.00	69,170.00	0.00%	69,170.00
Expense Total	0.00	5,764.13	(5,764.13)	0.00	69,170.00	0.00%	69,170.00

City of Rice
 Financial Statement
 As of September 30, 2024

207 - Court Reserves Carry Forward Y Court Reserves Carry Forward Y	Current Month Actual	Current Month Budget	Budget Variance	YTD Actual	Annual Budget	% Budget Used	Budget Remaining
207-20-4378 Court Reserves Carry	0.00	5,764.13	(5,764.13)	0.00	69,170.00	0.00%	69,170.00
Court Reserves Carry Forward Year End	0.00	5,764.13	(5,764.13)	0.00	69,170.00	0.00%	69,170.00
Expense Totals	0.00	5,764.13	(5,764.13)	0.00	69,170.00	0.00%	69,170.00

**City of Rice
Financial Statement
As of September 30, 2024**

240 - Donations	Current Month Actual	Current Month Budget	Budget Variance	YTD Actual	Annual Budget	% of Budget	Budget Remaining
Revenue Summary							
Grants & Donations	5,053.99	1,666.74	3,387.25	25,741.24	20,000.00	128.71%	(5,741.24)
Revenue Totals	5,053.99	1,666.74	3,387.25	25,741.24	20,000.00	128.71%	(5,741.24)
Expense Summary							
Community Programs & Donations	10,262.72	1,666.74	8,595.98	25,641.24	20,000.00	128.21%	(5,641.24)
Repairs & Maintenance	0.00	1,905.95	(1,905.95)	7,623.78	7,623.78	100.00%	0.00
Expense Totals	10,262.72	3,572.69	6,690.03	33,265.02	27,623.78	120.42%	(5,641.24)

City of Rice
 Financial Statement
 As of September 30, 2024

240 - Donations	Current Month Actual	Current Month Budget	Budget Variance	YTD Actual	Annual Budget	% of Budget	Budget Remaining
Grants & Donations							
240-4444 Donations - Rice Recreation	0.00	0.00	0.00	0.00	0.00	0.00%	0.00
240-4477 Donations -Events Parks & Rec	5,053.99	833.37	4,220.62	22,786.24	10,000.00	227.86%	(12,786.24)
240-4479 Donations- Library	0.00	833.37	(833.37)	2,955.00	10,000.00	29.55%	7,045.00
Grants & Donations Totals	5,053.99	1,666.74	3,387.25	25,741.24	20,000.00	128.71%	(5,741.24)
Revenue Totals	5,053.99	1,666.74	3,387.25	25,741.24	20,000.00	128.71%	(5,741.24)

**City of Rice
Financial Statement
As of September 30, 2024**

240 - Donations Parks and Recreation	Current Month Actual	Current Month Budget	Budget Variance	YTD Actual	Annual Budget	% Budget Used	Budget Remaining
Community Programs & Donations	10,262.72	833.37	9,429.35	22,786.24	10,000.00	227.86%	(12,786.24)
Parks and Recreation Totals	10,262.72	833.37	9,429.35	22,786.24	10,000.00	227.86%	(12,786.24)
240 - Donations Library	Current Month Actual	Current Month Budget	Budget Variance	YTD Actual	Annual Budget	% Budget Used	Budget Remaining
Community Programs & Donations	0.00	833.37	(833.37)	2,855.00	10,000.00	28.55%	7,145.00
Repairs & Maintenance	0.00	1,905.95	(1,905.95)	7,623.78	7,623.78	100.00%	0.00
Library Totals	0.00	2,739.32	(2,739.32)	10,478.78	17,623.78	59.46%	7,145.00
Expense Total	10,262.72	3,572.69	6,690.03	33,265.02	27,623.78	120.42%	(5,641.24)

City of Rice
 Financial Statement
 As of September 30, 2024

240 - Donations Parks and Recreation	Current Month Actual	Current Month Budget	Budget Variance	YTD Actual	Annual Budget	% Budget Used	Budget Remaining
240-40-4478 Donation Expense- Parks &	10,262.72	833.37	9,429.35	22,786.24	10,000.00	227.86%	(12,786.24)
Parks and Recreation Totals	10,262.72	833.37	9,429.35	22,786.24	10,000.00	227.86%	(12,786.24)

City of Rice
 Financial Statement
 As of September 30, 2024

240 - Donations Library	Current Month Actual	Current Month Budget	Budget Variance	YTD Actual	Annual Budget	% Budget Used	Budget Remaining
240-80-4480 Donations Library - Expense	0.00	833.37	(833.37)	2,855.00	10,000.00	28.55%	7,145.00
240-80-5426 Insurance Claim	0.00	1,905.95	(1,905.95)	7,623.78	7,623.78	100.00%	0.00
Library Totals	0.00	2,739.32	(2,739.32)	10,478.78	17,623.78	59.46%	7,145.00
Expense Totals	10,262.72	3,572.69	6,690.03	33,265.02	27,623.78	120.42%	(5,641.24)

City of Rice
 Financial Statement
 As of September 30, 2024

400 - Police Seizure Funds	Current Month Actual	Current Month Budget	Budget Variance	YTD Actual	Annual Budget	% of Budget	Budget Remaining
Revenue Summary							
Police Seizure Funds	0.00	1,668.58	(1,668.58)	0.00	20,022.85	0.00%	20,022.85
Revenue Totals	0.00	1,668.58	(1,668.58)	0.00	20,022.85	0.00%	20,022.85
Expense Summary							
Office & Supplies	0.00	221.62	(221.62)	0.00	2,659.00	0.00%	2,659.00
Operating Expense	0.00	833.37	(833.37)	0.00	10,000.00	0.00%	10,000.00
Personnel/Payroll	0.00	166.63	(166.63)	0.00	2,000.00	0.00%	2,000.00
Legal & Professional Fees	0.00	166.63	(166.63)	0.00	2,000.00	0.00%	2,000.00
Repairs & Maintenance	0.00	493.50	(493.50)	0.00	5,922.00	0.00%	5,922.00
Expense Totals	0.00	1,881.75	(1,881.75)	0.00	22,581.00	0.00%	22,581.00

City of Rice
 Financial Statement
 As of September 30, 2024

400 - Police Seizure Funds	Current Month Actual	Current Month Budget	Budget Variance	YTD Actual	Annual Budget	% of Budget	Budget Remaining
Police Seizure Funds							
400-7567 Seizure Fund Revenue	0.00	826.85	(826.85)	0.00	9,922.20	0.00%	9,922.20
400-7569 Police Seizure Funds Carry	0.00	841.73	(841.73)	0.00	10,100.65	0.00%	10,100.65
Police Seizure Funds Totals	0.00	1,668.58	(1,668.58)	0.00	20,022.85	0.00%	20,022.85
Revenue Totals	0.00	1,668.58	(1,668.58)	0.00	20,022.85	0.00%	20,022.85

City of Rice
Financial Statement
As of September 30, 2024

400 - Police Seizure Funds	Police Seizure Funds	Current Month Actual	Current Month Budget	Budget Variance	YTD Actual	Annual Budget	% Budget Used	Budget Remaining
	Legal & Professional Fees	0.00	166.63	(166.63)	0.00	2,000.00	0.00%	2,000.00
	Office & Supplies	0.00	221.62	(221.62)	0.00	2,659.00	0.00%	2,659.00
	Operating Expense	0.00	833.37	(833.37)	0.00	10,000.00	0.00%	10,000.00
	Personnel/Payroll	0.00	166.63	(166.63)	0.00	2,000.00	0.00%	2,000.00
	Repairs & Maintenance	0.00	493.50	(493.50)	0.00	5,922.00	0.00%	5,922.00
	Police Seizure Funds Totals	0.00	1,881.75	(1,881.75)	0.00	22,581.00	0.00%	22,581.00
	Expense Total	0.00	1,881.75	(1,881.75)	0.00	22,581.00	0.00%	22,581.00

City of Rice
 Financial Statement
 As of September 30, 2024

400 - Police Seizure Funds Police Seizure Funds	Current Month Actual	Current Month Budget	Budget Variance	YTD Actual	Annual Budget	% Budget Used	Budget Remaining
400-50-5201 Supplies	0.00	221.62	(221.62)	0.00	2,659.00	0.00%	2,659.00
400-50-5204 Equipment	0.00	833.37	(833.37)	0.00	10,000.00	0.00%	10,000.00
400-50-5206 Training Expense	0.00	166.63	(166.63)	0.00	2,000.00	0.00%	2,000.00
400-50-5219 Investigations	0.00	166.63	(166.63)	0.00	2,000.00	0.00%	2,000.00
400-50-5230 Facility	0.00	493.50	(493.50)	0.00	5,922.00	0.00%	5,922.00
Police Seizure Funds Totals	0.00	1,881.75	(1,881.75)	0.00	22,581.00	0.00%	22,581.00
Expense Totals	0.00	1,881.75	(1,881.75)	0.00	22,581.00	0.00%	22,581.00

City of Rice
 Financial Statement
 As of September 30, 2024

500 - Grant Programs	Current Month Actual	Current Month Budget	Budget Variance	YTD Actual	Annual Budget	% of Budget	Budget Remaining
Revenue Summary							
Grants & Donations	0.00	16,740.00	(16,740.00)	195,641.50	200,000.00	97.82%	4,358.50
Revenue Totals	0.00	16,740.00	(16,740.00)	195,641.50	200,000.00	97.82%	4,358.50
Expense Summary							
Grant Expense	0.00	16,740.00	(16,740.00)	203,801.50	200,000.00	101.90%	(3,801.50)
Expense Totals	0.00	16,740.00	(16,740.00)	203,801.50	200,000.00	101.90%	(3,801.50)

City of Rice
 Financial Statement
 As of September 30, 2024

10/1/2024 3:02 PM

500 - Grant Programs	Current Month Actual	Current Month Budget	Budget Variance	YTD Actual	Annual Budget	% of Budget	Budget Remaining
Grants & Donations							
500-4910 TXDOT Green Ribbon Grant	0.00	16,740.00	(16,740.00)	195,641.50	200,000.00	97.82%	4,358.50
Grants & Donations Totals	0.00	16,740.00	(16,740.00)	195,641.50	200,000.00	97.82%	4,358.50
Revenue Totals	0.00	16,740.00	(16,740.00)	195,641.50	200,000.00	97.82%	4,358.50

**City of Rice
 Financial Statement
 As of September 30, 2024**

500 - Grant Programs Grant Programs	Current Month Actual	Current Month Budget	Budget Variance	YTD Actual	Annual Budget	% Budget Used	Budget Remaining
Grant Expense	0.00	16,740.00	(16,740.00)	203,801.50	200,000.00	101.90%	(3,801.50)
Grant Programs Totals	0.00	16,740.00	(16,740.00)	203,801.50	200,000.00	101.90%	(3,801.50)
Expense Total	0.00	16,740.00	(16,740.00)	203,801.50	200,000.00	101.90%	(3,801.50)

City of Rice
 Financial Statement
 As of September 30, 2024

500 - Grant Programs Grant Programs	Current Month Actual	Current Month Budget	Budget Variance	YTD Actual	Annual Budget	% Budget Used	Budget Remaining
500-32-7771 American Rescue Plan Act-	0.00	0.00	0.00	8,160.00	0.00	0.00%	(8,160.00)
500-32-7777 TxDOT Green Ribbon Grant	0.00	16,740.00	(16,740.00)	195,641.50	200,000.00	97.82%	4,358.50
Grant Programs Totals	0.00	16,740.00	(16,740.00)	203,801.50	200,000.00	101.90%	(3,801.50)
Expense Totals	0.00	16,740.00	(16,740.00)	203,801.50	200,000.00	101.90%	(3,801.50)

City of Rice Financial Statement As of September 30, 2024

950 - Rice EDC	Current Month Actual	Current Month Budget	Budget Variance	YTD Actual	Annual Budget	% of Budget	Budget Remaining
Revenue Summary							
Sales & Property Taxes	3,715.00	4,500.00	(785.00)	57,470.20	45,000.00	127.71%	(12,470.20)
Other Revenue Sources	0.00	1,866.67	(1,866.67)	11,200.00	11,200.00	100.00%	0.00
Grants & Donations	0.00	5,000.00	(5,000.00)	50,000.00	50,000.00	100.00%	0.00
EDC Account Carry Forward Year End	0.00	11,126.84	(11,126.84)	0.00	132,936.00	0.00%	132,936.00
Revenue Totals	3,715.00	22,493.51	(18,778.51)	118,670.20	239,136.00	49.62%	120,465.80
Expense Summary							
Personnel/Payroll	0.00	1,841.40	(1,841.40)	5,453.01	22,000.00	24.79%	16,546.99
Office & Supplies	0.00	66.85	(66.85)	751.36	800.00	93.92%	48.64
Legal & Professional Fees	277.50	167.40	110.10	277.50	2,000.00	13.88%	1,722.50
Operating Expense	1,000.00	376.65	623.35	1,399.79	4,500.00	31.11%	3,100.21
Community Programs & Donations	0.00	7,425.88	(7,425.88)	42,854.67	66,700.00	64.25%	23,845.33
Not Categorized	0.00	5,000.00	(5,000.00)	50,000.00	50,000.00	100.00%	0.00
Capital	0.00	833.37	(833.37)	0.00	10,000.00	0.00%	10,000.00
Grant Expense	0.00	2,511.00	(2,511.00)	0.00	30,000.00	0.00%	30,000.00
EDC Reserves	0.00	4,447.58	(4,447.58)	16,849.43	53,136.00	31.71%	36,286.57
Expense Totals	1,277.50	22,670.13	(21,392.63)	117,585.76	239,136.00	49.17%	121,550.24

City of Rice
 Financial Statement
 As of September 30, 2024

950 - Rice EDC	Current Month Actual	Current Month Budget	Budget Variance	YTD Actual	Annual Budget	% of Budget	Budget Remaining
Sales & Property Taxes							
950-4132 4B Economic Development Sales	3,715.00	4,500.00	(785.00)	57,470.20	45,000.00	127.71%	(12,470.20)
Sales & Property Taxes Totals	3,715.00	4,500.00	(785.00)	57,470.20	45,000.00	127.71%	(12,470.20)
Other Revenue Sources							
950-4190 Other Income	0.00	1,866.67	(1,866.67)	11,200.00	11,200.00	100.00%	0.00
Other Revenue Sources Totals	0.00	1,866.67	(1,866.67)	11,200.00	11,200.00	100.00%	0.00
Grants & Donations							
950-4909 Rice EDC Home Town T-Mobile	0.00	5,000.00	(5,000.00)	50,000.00	50,000.00	100.00%	0.00
Grants & Donations Totals	0.00	5,000.00	(5,000.00)	50,000.00	50,000.00	100.00%	0.00
EDC Account Carry Forward Year End Estimated Balance							
950-8001 EDC Account Carry Forward Year	0.00	11,126.84	(11,126.84)	0.00	132,936.00	0.00%	132,936.00
EDC Account Carry Forward Year End Estimated Balance Totals	0.00	11,126.84	(11,126.84)	0.00	132,936.00	0.00%	132,936.00
Revenue Totals	3,715.00	22,493.51	(18,778.51)	118,670.20	239,136.00	49.62%	120,465.80

City of Rice Financial Statement As of September 30, 2024

950 - Rice EDC	Current	Current	Current	Budget	YTD	Annual	% Budget	Budget
EDC General Administration	Month Actual	Month Budget	Variance	Actual	Budget	Used	Remaining	
Capital	0.00	833.37	(833.37)	0.00	10,000.00	0.00%	10,000.00	
Community Programs & Donations	0.00	7,425.88	(7,425.88)	42,854.67	66,700.00	64.25%	23,845.33	
EDC Reserves	0.00	4,447.58	(4,447.58)	16,849.43	53,136.00	31.71%	36,286.57	
Grant Expense	0.00	2,511.00	(2,511.00)	0.00	30,000.00	0.00%	30,000.00	
Legal & Professional Fees	277.50	167.40	110.10	277.50	2,000.00	13.88%	1,722.50	
Not Categorized	0.00	5,000.00	(5,000.00)	50,000.00	50,000.00	100.00%	0.00	
Office & Supplies	0.00	66.85	(66.85)	751.36	800.00	93.92%	48.64	
Operating Expense	1,000.00	376.65	623.35	1,399.79	4,500.00	31.11%	3,100.21	
Personnel/Payroll	0.00	1,841.40	(1,841.40)	5,453.01	22,000.00	24.79%	16,546.99	
EDC General Administration Totals	1,277.50	22,670.13	(21,392.63)	117,585.76	239,136.00	49.17%	121,550.24	
Expense Total	1,277.50	22,670.13	(21,392.63)	117,585.76	239,136.00	49.17%	121,550.24	

City of Rice
 Financial Statement
 As of September 30, 2024

950 - Rice EDC EDC General Administration	Current Month Actual	Current Month Budget	Budget Variance	YTD Actual	Annual Budget	% Budget Used	Budget Remaining
950-10-5109 Contract Labor	0.00	1,255.50	(1,255.50)	4,705.00	15,000.00	31.37%	10,295.00
950-10-5201 Office Supplies	0.00	41.85	(41.85)	474.87	500.00	94.97%	25.13
950-10-5202 Printing Supplies	0.00	16.63	(16.63)	262.79	200.00	131.40%	(62.79)
950-10-5203 Postage	0.00	8.37	(8.37)	13.70	100.00	13.70%	86.30
950-10-5206 Training Expense	0.00	585.90	(585.90)	748.01	7,000.00	10.69%	6,251.99
950-10-5223 Audit Expense	0.00	83.70	(83.70)	0.00	1,000.00	0.00%	1,000.00
950-10-5224 Legal and Professional Fees	277.50	83.70	193.80	277.50	1,000.00	27.75%	722.50
950-10-5227 Advertising	0.00	292.95	(292.95)	399.79	3,500.00	11.42%	3,100.21
950-10-5229 Public & Employee Relations	0.00	209.25	(209.25)	2,399.97	2,500.00	96.00%	100.03
950-10-5375 Rice EDC T-Mobile Home	0.00	5,000.00	(5,000.00)	50,000.00	50,000.00	100.00%	0.00
950-10-5452 Hardware/Software	1,000.00	83.70	916.30	1,000.00	1,000.00	100.00%	0.00
950-10-5700 Property Acquisitions	0.00	833.37	(833.37)	0.00	10,000.00	0.00%	10,000.00
950-10-5702 Business Improvement	0.00	2,511.00	(2,511.00)	0.00	30,000.00	0.00%	30,000.00
950-10-8009 EDC Reserves	0.00	4,447.58	(4,447.58)	16,849.43	53,136.00	31.71%	36,286.57
950-10-9501 Recreational Improvements	0.00	4,966.63	(4,966.63)	28,454.70	37,200.00	76.49%	8,745.30
950-10-9502 EDC Property Improvements	0.00	1,250.00	(1,250.00)	0.00	15,000.00	0.00%	15,000.00
950-10-9503 Additional Development	0.00	1,000.00	(1,000.00)	12,000.00	12,000.00	100.00%	0.00
EDC General Administration Totals	1,277.50	22,670.13	(21,392.63)	117,585.76	239,136.00	49.17%	121,550.24
Expense Totals	1,277.50	22,670.13	(21,392.63)	117,585.76	239,136.00	49.17%	121,550.24

City of Rice
 Financial Statement
 As of September 30, 2024

10/1/2024 3:02 PM

988 - City Reserves	Current Month Actual	Current Month Budget	Budget Variance	YTD Actual	Annual Budget	% of Budget	Budget Remaining
Revenue Summary							
Savings Account Carry Forward Year End	0.00	16,815.05	(16,815.05)	0.00	200,895.43	0.00%	200,895.43
Revenue Totals	0.00	16,815.05	(16,815.05)	0.00	200,895.43	0.00%	200,895.43
Expense Summary							
City Reserves	0.00	16,815.05	(16,815.05)	0.00	200,895.43	0.00%	200,895.43
Expense Totals	0.00	16,815.05	(16,815.05)	0.00	200,895.43	0.00%	200,895.43

City of Rice
 Financial Statement
 As of September 30, 2024

988 - City Reserves	Current Month Actual	Current Month Budget	Budget Variance	YTD Actual	Annual Budget	% of Budget	Budget Remaining
Savings Account Carry Forward Year End Estimated Balance							
988-8002 Savings Account Carry Forward	0.00	16,815.05	(16,815.05)	0.00	200,895.43	0.00%	200,895.43
Savings Account Carry Forward Year End Estimated Balance Totals	0.00	16,815.05	(16,815.05)	0.00	200,895.43	0.00%	200,895.43
Revenue Totals	0.00	16,815.05	(16,815.05)	0.00	200,895.43	0.00%	200,895.43

City of Rice
 Financial Statement
 As of September 30, 2024

10/1/2024 3:02:57 PM

988 - City Reserves Reserve Funds	Current Month Actual	Current Month Budget	Budget Variance	YTD Actual	Annual Budget	% Budget Used	Budget Remaining
City Reserves	0.00	16,815.05	(16,815.05)	0.00	200,895.43	0.00%	200,895.43
Reserve Funds Totals	0.00	16,815.05	(16,815.05)	0.00	200,895.43	0.00%	200,895.43
Expense Total	0.00	16,815.05	(16,815.05)	0.00	200,895.43	0.00%	200,895.43

City of Rice
Financial Statement
As of September 30, 2024

988 - City Reserves Reserve Funds	Current Month Actual	Current Month Budget	Budget Variance	YTD Actual	Annual Budget	% Budget Used	Budget Remaining
988-98-8003 City Reserves	0.00	16,815.05	(16,815.05)	0.00	200,895.43	0.00%	200,895.43
Reserve Funds Totals	0.00	16,815.05	(16,815.05)	0.00	200,895.43	0.00%	200,895.43
Expense Totals	0.00	16,815.05	(16,815.05)	0.00	200,895.43	0.00%	200,895.43



9. **NEW BUSINESS**
 - a. Presentation of the Fall Festival check to the Rice Volunteer Fire Department



9b. Discuss and Deliberate disposing of city property



- 9c.** Discuss and Deliberate adopting Resolution 2024-10-17: Policy mandated by SB 1863

RESOLUTION NO: 2024-10-17

A RESOLUTION OF THE CITY COUNCIL OF THE CITY OF RICE, NAVARRO COUNTY, TEXAS, APPROVING THE TERMS OF S.B. 1863, ADOPTING POLICIES PROHIBITING TIK TOK ON GOVERNMENT DEVICES BY NOVEMBER 20, 2024.

1.0 INTRODUCTION

On December 7, 2022, Governor Greg Abbott required all state agencies to ban the video-sharing application TikTok from all state-owned and state-issued devices and networks over the Chinese Communist Party's ability to use the application for surveilling Texans. Governor Abbott also directed the Texas Department of Public Safety (DPS) and the Texas Department of Information Resources (DIR) to develop a plan providing state agencies guidance on managing personal devices used to conduct state business. Following the issuance of the Governor's directive, the 88th Texas Legislature passed [Senate Bill 1893](#), which prohibits the use of covered applications on governmental entity devices.

As required by the Governor's directive and Senate Bill 1893, this policy prohibits the installation or use of covered applications or prohibited technologies on applicable devices.

2.0 COVERED APPLICATIONS POLICY FOR CITY OF RICE

2.1 SCOPE AND DEFINITIONS

Pursuant to Senate Bill 1893, this policy applies to all City of Rice full- and part-time employees, contractors, paid or unpaid interns, and other users of government networks. All City of Rice employees are responsible for complying with this policy.

Under this policy, a covered application is:

- The social media service TikTok or any successor application or service developed or provided by ByteDance Limited, or an entity owned by ByteDance Limited.
- A social media application or service specified by proclamation of the governor under Government Code Section 620.005.

2.2 COVERED APPLICATIONS ON CITY OF RICE-OWNED OR LEASED DEVICES

Except where approved exceptions apply, the use or installation of covered applications is prohibited on all City of Rice-owned or -leased devices, including cell phones, tablets, desktop and laptop computers, and other internet-capable devices.

The City of Rice will identify, track, and manage all government-owned or -leased devices including mobile phones, tablets, laptops, desktop computers, or any other internet-capable devices to:

- a. Prohibit the installation of a covered application.
- b. Prohibit the use of a covered application.
- c. Remove a covered application from a City of Rice-owned or -leased device that was on the device prior to the passage of S.B. 1893 (88th Leg, R.S.).
- d. Remove an application from a City of Rice-owned or -leased device if the Governor issues a proclamation identifying it as a covered application.

The City of Rice will manage all City-owned or leased mobile devices by implementing one or more of the security measures listed below:

- a. Restrict access to "app stores" or unauthorized software repositories to prevent the installation of unauthorized applications.
- b. Maintain the ability to remotely wipe non-compliant or compromised mobile devices.
- c. Maintain the ability to remotely uninstall unauthorized software from mobile devices.
- d. Other City-implemented security measures.

2.3 ONGOING AND EMERGING TECHNOLOGY THREATS

To provide protection against ongoing and emerging technological threats to the State's sensitive information and critical infrastructure, DPS and DIR will regularly monitor and evaluate additional social media applications or services that pose a risk to this state.

DIR will annually submit to the Governor a list of social media applications and services identified as posing a risk to Texas. The Governor may proclaim items on this list as covered applications that are subject to this policy.

If the Governor identifies an item on the DIR-posted list described by this section, then the City of Rice will remove and prohibit the covered application.

The City of Rice may also prohibit social media applications or services in addition to those specified by proclamation of the Governor.

2.4 BRING YOUR OWN DEVICE POLICY

If the City of Rice has a "Bring Your Own Device" (BYOD) program, then the City of Rice may consider prohibiting the installation or operation of covered applications on employee-owned devices that are used to conduct government business.

2.5 COVERED APPLICATION EXCEPTIONS

The City of Rice may permit exceptions authorizing the installation and use of a covered application on City-owned or -leased devices consistent with the authority provided by Government Code Chapter 620.

Government Code Section 620.004 only allows the City of Rice to install and use a covered application on an applicable device to the extent necessary for:

- (1) Providing law enforcement; or
- (2) Developing or implementing information security measures.

If the City of Rice authorizes an exception allowing for the installation and use of a covered application, the City must use measures to mitigate the risks posed to the state during the application's use including measures that the City deems appropriate for its own policy. The City of Rice must document whichever measures it took to mitigate the risks posed to the state during the use of the covered application.

3.0 POLICY COMPLIANCE

The City of Rice will verify compliance with this policy through various methods, including but not limited to, IT/security system reports and feedback to leadership.

An employee found to have violated this policy may be subject to disciplinary action, including termination of employment.

4.0 POLICY REVIEW

This policy will be reviewed annually and updated as necessary to reflect changes in state law, additions to applications identified under Government Code Section 620.006, updates to the prohibited technology list posted to DIR's website, or to suit the needs of the City of Rice.

4856-8796-3883, v. 1



CITY OF RICE

Covered Applications and Prohibited Technology Resolution

Date: October 17, 2024

Version: 1.0



9d. Discuss and Deliberate adopting ordinance for No-Thru-Traffic.

This will help prevent large trucks driving through town when there is an incident on Interstate 45



9e. Discuss and Deliberate a date for a workshop



10. OLD BUSINESS

- a. Discuss and Deliberate approval of purchasing road maintenance equipment



North Frisco 10PM

75033

Wh...



North Frisco 10PM

75033



Shop All Services



DIY



Log In

Home / Outdoors / Outdoor Power Equipment / Plate Compactors

Customers Also Viewed

Best Seller



YARDMAX

1850 lb. Compaction Force Plate Compactor

★★★★☆ (4 / 222)

\$377⁹⁹

Top Rated



YARDMAX

3000 lb. Compaction Force Plate Compactor Briggs and Stratton 6.5HP/208cc

★★★★☆ (4.4 / 74)

\$666⁵⁴



Feedback

< 1/6 >



STARK USA

2000 lbs. Compaction Force Plate Compactor and Vibratory Asphalt/Soil Rammer

★★★★☆ (17) Questions & Answers (3)

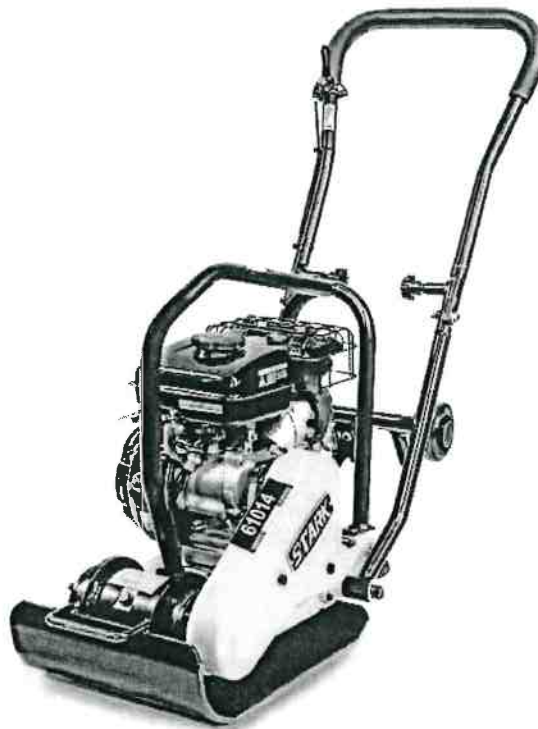

Hover Image to Zoom

Share Print



North Frisco 10PM

75033

Wh...



North Frisco 10PM

75033

Shop All Services



DIY

Log In

Home / Outdoors / Outdoor Power Equipment / Plate Compactors

Customers Also Viewed



WEN
7 HP 4500-Pound Compaction Force Plate Compactor, CARB Compliant

★★★★☆ (4.2 / 353)

\$651²⁰



Tomahawk Power
2 HP Electric Vibratory Plate Compactor
Tampers Gravel Soil Compaction

\$1300⁰⁰ /box

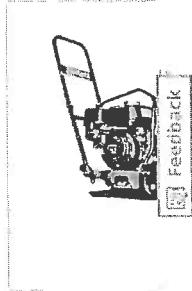

< 1/6 >

♡ 22

Tomahawk Power

5.5 HP Honda Powered Gas Plate Compactor for Asphalt, Soil Compaction

★★★★☆ (23) Questions & Answers (15)

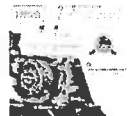

Hover Image to Zoom

Share Print

\$1699⁹⁹ /box

 \$284.00/mo** suggested payments with 6 months** financing [Apply Now](#) ⓘ

- 3-year warranty with reliable 5.5 HP Honda GX160 engine
- Compaction depth of 3,000 lbs./ft.²
- 21 in. x 17 in. steel base plate
- [View More Details](#)

Pickup at North Frisco

Delivering to 75033

Ship to Store Oct 16 - Oct 17 53 available FREE	Delivery Oct 16 - Oct 28 53 available FREE
--	---

 Feedback

- 1 + [Add to Cart](#)

rayon

As low as \$91.57/mo. with **PayPal**. [Learn more](#)

 **Free & Easy Returns In Store or Online**
Return this item within **30 days** of purchase. [Read Return Policy](#)

Loading Recommendations

Days Miles Hours Blows

03	16	42	49
----	----	----	----



5.5HP HONDA GX160 ENGINE

Durable and tough, this plate compactor is built to last, making it perfect for professionals, construction equipment rental, and do-it-yourselfers alike.



COMPACTION FORCE OF 3,000 LBS/FT

Achieve 100% Compaction Ratings at 6,400 blows/min, required for nuclear density testing and field compaction tests.



NORTHERN[®]
TOOL + EQUIPMENT

TAKE \$25 OFF YOUR ORDER OF \$250 OR MORE

< [Compaction Equipment](#) / [Item# 71968](#)

Husqvarna Forward Plate Compactor, 4.8 HP, 17in., Model# LF75 17

[Write a Review](#)

(0) [Write a Review](#) [Ask a Question](#)



 CHAT

\$2452.40

 **PayPal** As low as \$132.10/mo. [Learn more](#)

Quantity

Qty: 1 

Add to Cart

 Save to List



Shipping:

Factory shipped

[See Shipping Options](#)



Store Pickup:

Not available - online only

- Efficient compaction thanks to a powerful 4.8 HP Honda GX160 engine
- Efficient, patented low-vibration handle lowers the vibration levels below 2 m/s², allowing you to work for hours without becoming fatigued or exceeding any regulatory threshold limit values
- Watering system prevents the bottom plate from sticking to the hot asphalt
- Minimal water usage thanks to the easily adjustable water flow
- Large, corrosion-free water tank and smart water distribution system enable you to work longer with fewer stops for re-filling

[See full description](#)

CHAT

Complete Your Solution



item#	71968	Engine Model	GX160
Brand	Husqvarna	Product Type	Plate Compactor
Manufacture's Warranty	12 months parts/12months labor	Plate Length	22.4 in
		Plate Width	16.5 in
Ship Weight	215.0 LB	Travel Speed	89 ft./min.
Horsepower	4.8 HP	Product Weight	215 lb
Engine Brand	Honda		

How can we improve these key specs?

Accessories We Recommend

CHAT



BUYER'S ORDER

Happy Trailers

1911 S I-45 Service Rd

Phone: (972) 845-1003 Fax: () -

Salesperson:

Deal #:-113445

Delivery Date:

Buyer Name(s) & Information

Buyer: City of Rice
Co-Buyer:
Address:
City, State Zip: Rice, TX

Phone (Home):
Phone (Cell): (903) 875-8460
Email: eaton.tom62@yahoo.com
Cust. Number: 1050450

Bumper Pull

Retail Unit		Itemization	
Description (Year/Manufacturer/Make/Model) N/U/D:NEW		Base Selling Price:	10599.00
2024 PJ Trailers DM	Type: Dump	PDI Dump/Utility/SDX:	N/A
VIN: 4P51D1924R1410526	Odometer:	:	N/A
Color: BLACK	GVW: 14000	:	N/A
Stock Number: 410526	Price: \$ 10599.00	:	N/A
Trade 1		:	N/A
Description (Year/Manufacturer/Make/Model)		:	N/A
	Type:	Total Accessories:	N/A
VIN:	Odometer:	Retail Discount:	N/A
Color:	GVW:	SUBTOTAL:	10599.00
Payoff Name:		State Tax:	N/A
Payoff Address:		County Tax:	N/A
Phone:	Amt Owed: \$ 0.00	City Tax:	N/A
Trade 2		:	N/A
Description (Year/Manufacturer/Make/Model)		Total Sales Tax:	N/A
	Type:	SUBTOTAL:	10599.00
VIN:	Odometer:	Documentation Fees:	150.00
Color:	GVW:	:	N/A
Payoff Name:		:	N/A
Payoff Address:		:	N/A
Phone:	Amt Owed: \$ 0.00	:	N/A
Retail Lienholder		:	N/A
Name:		:	N/A
Address:		:	N/A
Phone:	Account #:	Total Fees:	150.00
Insurance		SUBTOTAL:	10749.00
Company:	Policy #:	:	N/A
Agent:	Phone:	:	N/A
Eff. Date:	Exp. Date:	:	N/A
Comments		:	N/A
customer is responsible for registering trailer		:	N/A
		Total Products:	N/A
		SUBTOTAL:	10749.00
		Trade Allowance:	N/A
		Amount Owed On Trade:	N/A
		Net Trade:	N/A
		Manufacturer Rebate:	N/A
		Cash Down Payment:	N/A
		Cash On Delivery:	N/A
		Total Down Payment:	N/A
		TOTAL BALANCE DUE:	10749.00

08/28/2024

08/28/2024

08/28/2024

Buyer

Date

Co-Buyer

Date

Dealer/Agent

Date



Happy Trailers

1911 S I-45 Service Rd
Phone: (972) 845-1003 Fax: () -

BUYER'S ORDER

Salesperson:

Deal #:-113443

Delivery Date:

Buyer Name(s) & Information

Buyer: City of Rice
Co-Buyer:
Address:
City, State Zip: Rice, TX

Phone (Home):
Phone (Cell): (903) 875-8460
Email: eaton.tom62@yahoo.com
Cust. Number: 1050450

Gooseneck

Retail Unit		Itemization	
Description (Year/Manufacturer/Make/Model) N/U/D:NEW		Base Selling Price:	11999.00
2024 PJ Trailers DM	Type: Dump	PDI Dump/Utility/SDX:	N/A
VIN: 4P53D242XR1411640	Odometer:	:	N/A
Color: BLACK	GVW: 15680	:	N/A
Stock Number: 411640	Price: \$ 11999.00	:	N/A
Trade 1		:	N/A
Description (Year/Manufacturer/Make/Model)		:	N/A
	Type:	Total Accessories:	N/A
VIN:	Odometer:	Retail Discount:	N/A
Color:	GVW:	SUBTOTAL:	11999.00
Payoff Name:		State Tax:	N/A
Payoff Address:		County Tax:	N/A
Phone:	Amt Owed: \$ 0.00	City Tax:	N/A
Trade 2		:	N/A
Description (Year/Manufacturer/Make/Model)		Total Sales Tax:	N/A
	Type:	SUBTOTAL:	11999.00
VIN:	Odometer:	Documentation Fees:	150.00
Color:	GVW:	Delivery Fee:	250.00
Payoff Name:		:	N/A
Payoff Address:		:	N/A
Phone:	Amt Owed: \$ 0.00	:	N/A
Retail Lienholder		:	N/A
Name:		:	N/A
Address:		:	N/A
Phone:	Account #:	Total Fees:	400.00
Insurance		SUBTOTAL:	12399.00
Company:	Policy #:	:	N/A
Agent:	Phone:	:	N/A
Eff. Date:	Exp. Date:	:	N/A
Comments		:	N/A
Customer is responsible for registering trailer.		:	N/A
		Total Products:	N/A
		SUBTOTAL:	12399.00
		Trade Allowance:	N/A
		Amount Owed On Trade:	N/A
		Net Trade:	N/A
		Manufacturer Rebate:	N/A
		Cash Down Payment:	N/A
		Cash On Delivery:	N/A
		Total Down Payment:	N/A
		TOTAL BALANCE DUE:	12399.00

08/28/2024

08/28/2024

08/28/2024

Buyer

Date

Co-Buyer

Date

Dealer/Agent

Date

Happy TRAILERS

[Inventory \(/all-inventory\)](#)

[Service \(/service\)](#)

[Financing \(/financing\)](#)

[Brands \(/brands\)](#)

[Truck Beds \(/brands/pj-truck-beds\)](#)

[Rentals \(/rentals\)](#)

[Contact \(/contact-us\)](#)

Have a Question?



2025 PJ 83"x14' BP Tandem Axle Low Pro Dump w/ 24" Sides - DL

Stock #412376

~~Our Price: \$9,499.00~~

Sale Price: \$8,499.00

or as low as \$175/mo

Greenville, TX
[\(/contact-us/locations/greenville\)](#)

(903) 455-0855
(tel:+19034550855)

Buy Now

Have a Question?

Trailer Overview

VIN:	4P51D1922S1412376
Condition:	new
Year:	2025
Manufacturer:	PJ Trailers
Model:	DL
Floor Length:	14' or 168.00"
Width:	6' 11" or 83.00"
Weight:	3970 lbs
GVWR:	14000 lbs
Payload Capacity:	10030 lbs
Axle Capacity:	7000 lbs

Financing or Rent to Own

Down Payment	\$ 0
Amount to be financed	\$8,649.00
Term (loan length)	36 Months
Your credit score	Good (670 - 699)
APR	13.74%
Est. Monthly Payment	\$295

Receive payments tailored to you without affecting your credit score.

Happy TRAILERS

[Inventory \(/all-inventory\)](#)

[Service \(/service\)](#)

[Financing \(/financing\)](#)

[Brands \(/brands\)](#)

[Truck Beds \(/brands/pj-truck-beds\)](#)

[Rentals \(/rentals\)](#)

[Contact \(/contact-us\)](#)

Have a Question?



USED 2019 83"x12' PJ Trailers Dump- DL

Stock #308658-2

~~Our Price: \$10,599.00~~

Sale Price: \$8,399.00

or as low as \$173/mo

[Seminole, TX \(/contact-us/locations/seminole\)](#)

[\(432\) 955-6990](#)

[\(tel:+14329556990\)](#)

Buy Now

Have a Question?

Trailer Overview

VIN:	4P5DL1224K1308658
Condition:	used
Year:	2019
Manufacturer:	PJ Trailers
Model:	DL
Floor Length:	12' or 144.00"
Width:	6' 11" or 83.00"
Weight:	4420 lbs
GVWR:	15680 lbs
Payload Capacity:	11260 lbs
Axle Capacity:	7000 lbs

Financing or Rent to Own

Happy TRAILERS

[Inventory \(/all-inventory\)](#)

[Service \(/service\)](#)

[Financing \(/financing\)](#)

[Brands \(/brands\)](#)

[Truck Beds \(/brands/pj-truck-beds\)](#)

[Rentals \(/rentals\)](#)

[Contact \(/contact-us\)](#)

[Have a Question?](#)



2024 PJ 83"x14' BP Tandem Axle Low Pro Dump w/ 24" Sides - DL

Stock #407879

Our Price: ~~\$9,499.00~~

Sale Price: **\$8,499.00**

or as low as \$175/mo

[El Paso, TX \(/contact-us/locations/el-paso-west-texas\)](#)

[\(915\) 455-2855](#)

[\(tel:+19154552855\)](#)

[Buy Now](#)

[Have a Question?](#)

Trailer Overview

VIN:	4P51D1920R1407879
Condition:	new
Year:	2024
Manufacturer:	PJ Trailers
Model:	DL
Floor Length:	14' or 168.00"
Width:	6' 11" or 83.00"
Weight:	3970 lbs
GVWR:	14000 lbs
Payload Capacity:	10030 lbs
Axle Capacity:	7000 lbs

Financing or Rent to Own

Down Payment	\$ 0
Amount to be financed	\$8,649.00
Term (loan length)	36 Months
Your credit score	Good (670 - 699)
APR	13.74%
Est. Monthly Payment	\$295

Receive payments tailored to you without affecting your credit score.

Happy TRAILERS

[Inventory \(/all-inventory\)](#)

[Service \(/service\)](#)

[Financing \(/financing\)](#)

[Brands \(/brands\)](#)

[Truck Beds \(/brands/pj-truck-beds\)](#)

[Rentals \(/rentals\)](#)

[Contact \(/contact-us\)](#)

Have a Question?



PRICE INCLUDES REBATE OFFER

2025 PJ 83"x14' BP Tandem Axle Low Pro Dump w/ 24" Sides - DL

Stock #417233

Our Price: ~~\$9,499.00~~

Sale Price: \$8,499.00

or as low as \$175/mo

Ferris, TX [\(/contact-us/locations/ferris\)](#)

(972) 845-1003
(tel:+19728451003)

Buy Now

Have a Question?

Trailer Overview

VIN:	4P51D1925S1417233
Condition:	new
Year:	2025
Manufacturer:	PJ Trailers
Model:	DL
Floor Length:	14' or 168.00"
Width:	6' 11" or 83.00"
Weight:	3970 lbs
GVWR:	14000 lbs
Payload Capacity:	10030 lbs
Axle Capacity:	7000 lbs

Financing or Rent to Own

Down Payment	\$ 0
Amount to be financed	\$8,649.00
Term (loan length)	36 Months
Your credit score	Good (670 - 699)
APR	13.74%
Est. Monthly Payment	\$295

Receive payments tailored to you without affecting your credit score.

Get Pre-Qualified

C-5 TRAILERS, INC.
 5027 S. Interstate Hwy. 45
 ENNIS, TX 75119
 (972)875-1095 PHONE
 (972)875-7159 FAX

Estimate

Date	Estimate #
9/6/2024	24-7928

Name / Address
RICE WATER SUPPLY, 2000 E. CALHOUN ST. RICE TX 75155

Project

Description	Qty	Cost	Total
83 x 14 Gooseneck Dump 2- 8k Hybrid Brakes 2- 10k Jacks 3' Solid Sides Tarp Kit Spreader Grate Ramps 235/16-14ply Tires Spare Tire 10 Ton Scissor Lift Hoist 8" I-Beam Main Frame 10" I-Beam Neck and Uprights Black (price doesn't include TTL)	1	13,750.00	13,750.00
		0.00%	0.00
		Total	\$13,750.00

Customer Signature _____

Date: 8/28/24 Driver: _____



Bill of Sale

Items Purchased, SN, Amount

24' boom truck 83x14x3

7R Dexter Axles w/ Brake

Tarp

Spare tire

D-Rings

Slide in ramps

Beam Doors + Dump Truck Tail Gate

\$11,220⁰⁰ plus fees

Buyer

Name City of Rice

Address _____

City, ST, Zip _____

Phone _____

Signature _____

I certify that I am the owner of the above listed goods, merchandise, and/or property and have good title and the right to sell and that they are free from any incumbrances. I agree to accept all responsibility for providing merchantable title for delivery of title to purchaser

Seller

Name C & L Equipment Sales

Address 2700 SWMCKinney

City, ST, Zip Rice, TX 75155

Phone 903-326-5802

DL and Exp _____

Signature Wade H

Subscribed and sworn to me

Before this _____ Day of _____,

Notary Public

Everything is sold as is, where is with no warranty implied.

Asphalt Zipper

420X^{GEN}₈

WITH ACCU-TRAK[™] WHEEL ASSIST



Shown with optional
150 gallon Wheel
Assist Mount water
supply system

42" Cutting Width Reclaimer/Stabilizer and Utility Trencher with PATENTED ZipTec[™] Enhanced Pulverizing System and Accu-Trak[™] Wheel Assist

BACKHOE MOUNT

SMALLER LOADER MOUNT

Packed with technology, yet surprisingly simple to operate, the NEW 8th Generation 420X WA harnesses the power and productivity of much larger, self-propelled reclaimers into a very powerful, versatile, and affordable loader attachment. Powered by the latest Cummins intercooled turbo-diesel **Tier 4 Final Performance Series** engine, the 420X WA will pulverize up to 10-inch-thick asphalt in a single pass. The innovative upgrades and improvements throughout this new-generation Asphalt Zipper dramatically improve production in thicker asphalt, reliability and longevity of the machine, and ease of use. Full road repairs, street patches, base stabilization, and opening utility trenches in asphalt are just a few of its many uses.

Completely Re-engineered, with New P

150 gallon Wheel Assist Mount water supply system

(optional) for an on-board, steady supply of water



**Cummins 173 hp
Tier 4 Final
Performance Series
engine** for quieter,
cleaner power

**Upgraded control panel and
wireless remote** with expanded
functionality

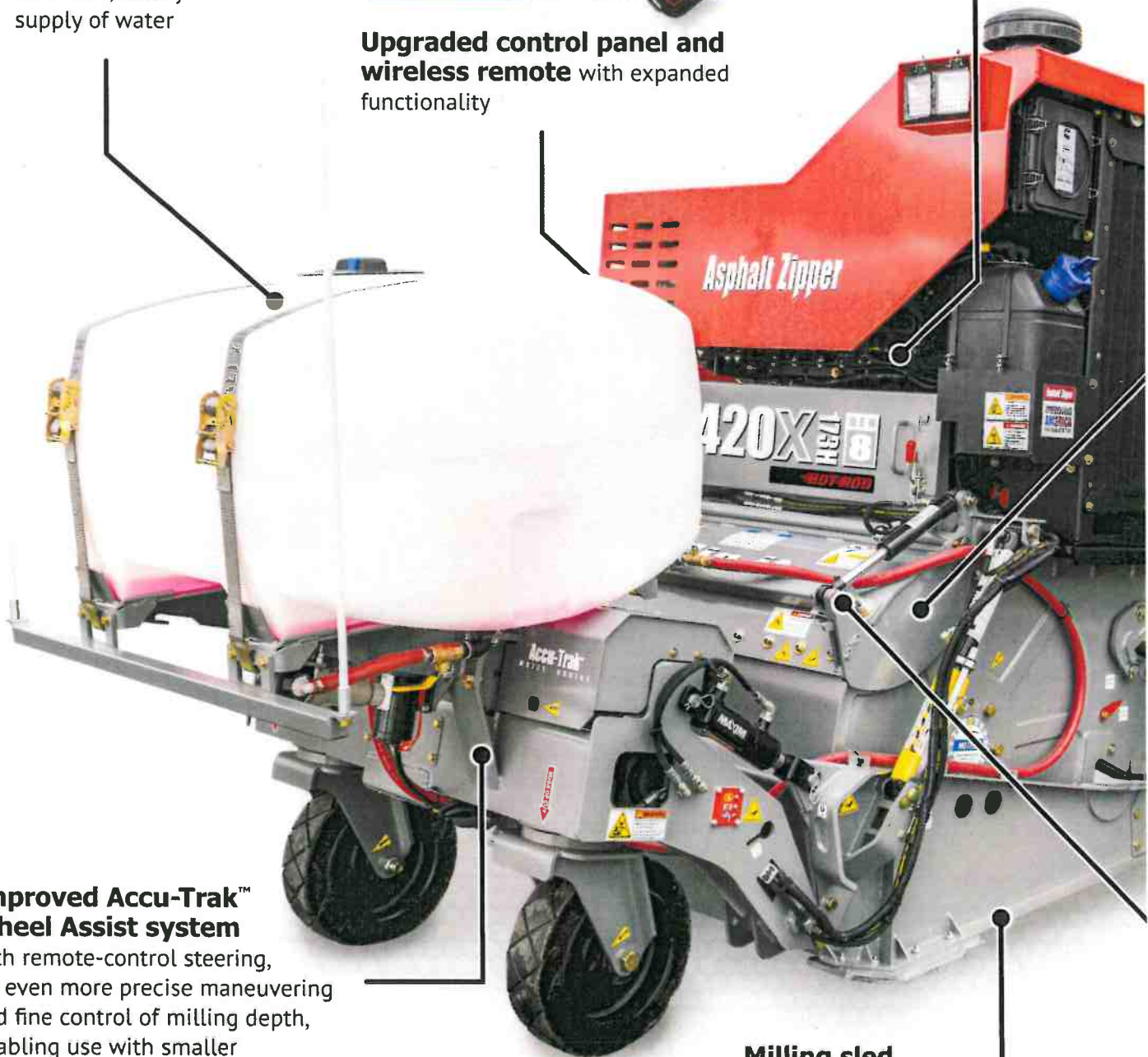

Improved Accu-Trak™ Wheel Assist system

with remote-control steering,
for even more precise maneuvering
and fine control of milling depth,
enabling use with smaller
host vehicles

Milling sled
for easier leveling

Features and Improvements Throughout

Hydraulically secured top hatch with automatic latching and overload protection

Hydraulically activated auto-adjusting clutch, remote engage, and loader operator's safety stop

Improved X cutter head for greater production with better material gradation

Heavier-duty planetary / gear box for even greater durability

Hardox®-reinforced steel frame with greater internal abrasion resistance, for longer life

Hydraulic safety-chain system ensures secure connection to host vehicle

Full-range depth adjustment, independent of the loader

Automatic hydraulic belt tensioning that is dynamically self-adjusting and releases tension when not in use, for greater longevity

Wireless control box for cab of host vehicle for quicker, more convenient installation and disconnection, with improved display

Innovative liquid cooling jacket for up to 5X improved planetary cooling

Anti-chunking material channeller that improves material containment for finer material

Quick-Load™ guiding system on all custom trailers, for easier loading

And much more ...



Integrated ZipTec™ Enhanced Pulverizing System, with full depth range, contained grinding chamber, and a remote-controlled active-hydraulic adjustable baffle for regulating material size



Top hatch adjustable breaker bar that works with Zip-Tec™ to fine-tune pulverization



Custom tandem-axle trailer (optional) with quick-load guiding system, low center of gravity, convenient working deck, and built-in custom toolbox enables the 420X WA to be hauled behind a 1-ton pickup truck.

NEW Wireless Control Box with E-Stop and tachometer gives host vehicle operator control over select Zipper functions.

Specifications

Model	420X-173H WA GEN 8
Engine	 Cummins 173 hp Turbo-Diesel  Performance Series
Torque	457 ft·lb <hr/> 620 N·m
Weight	7000 lbs <hr/> 3175 kg
Cutting Width	42 inches (30 inches available) <hr/> 1067 mm (762 mm available)
Cutting Depth	0 to 10 in <hr/> 0 to 254 mm

Asphalt Zipper reserves the right to change specifications at any time. U.S. patent nos. 7036252, 7066555, 7144087, 8177456, 10086867. Other U.S. and international patents pending.

Asphalt Zipper

World Leader in Portable Reclaimers/Stabilizers and Utility Trenchers



Toll-free: 888-ZIPPER-8 (947-7378)

310 West 700 South, Pleasant Grove, UT 84062
 Main: 801-847-3200 • Fax: 801-847-3250

AsphaltZipper.com

Standard Features

Cutter Head	420X/300X
Cutting Bits	Double-carbide, bullet-head
Containment System	ZipTec™ Enhanced Pulverizing System with active-hydraulic rear baffle
Planetary	Fairfield Magnum-duty
Depth Control	Hydraulic (infinitely adjustable)
Rear Baffle	Infinitely adjustable, active-hydraulic, remote-controlled
Bit Hatch	Hydraulically powered , top-access, with hydraulic clamping and shock absorption
Mounting System	Versa-Mount™ Universal Coupler with chain tensioning system
Controls and Monitoring	<ul style="list-style-type: none"> Control Panel (on machine) Wireless Control Box (for host vehicle) Wireless Remote Control (for groundsmen)
Transport	Tows behind 1-ton pickup on tandem-axle trailer.
Additional Features	<ul style="list-style-type: none"> Accu-Trak™ Wheel Assist Built-in spray system Hydraulic belt tensioning Planetary cooling jacket

Available Options

Side Shift and Tilt

Optional Mounting Systems:

- Quick Coupler
- Versa-Mount™ Quick Coupler

Water Supply Systems:

- Wheel Assist Mount (150 gallon)

Custom Trailer

Product Specifications

LeeBoy HB4T Hot Box

The following specifications are based on the HB4T Hot Box manufactured by LeeBoy. Because of continuous equipment research and development, we reserve the right to change these specifications. For more information, questions or assistance preparing specifications, please contact your local LeeBoy sales representative.

**Published Weights are approximate weight and will vary contingent on options.*

*** Options and specifications subject to change as LeeBoy optimizes productivity and improvements.*

- 1. Dimensions (trailer configuration):**
 - a. Length: 17' 10"
 - b. Width: 6' 9"
 - c. Height: 7' 8"

- 2. Hopper:**
 - a. Capacity: 4 tons or 8,000 lbs
 - b. Dimensions: 72" x 64" x 51"
 - c. Constructed of 11ga and 12ga steel
 - d. Triple wall hopper
 - e. 2" Insulation

- 3. Trailer:**
 - a. 7,000 lb axles with a pintle eye
 - b. 5,000 lb jackleg
 - c. Wired for towing
 - d. Tires: ST 235/80R16
 - e. Electric brakes on axles
 - f. Emergency breakaway switch with battery backup
 - g. Shipping Weight: 5,000 lbs
 - h. Loaded Weight: 12,700 lbs

- 4. Material Loading Doors:**
 - a. Dimensions: 65" x 36.69" x 2"
 - b. Hinge constructed of two bearings per door
 - c. Cantilever handle
 - d. Gas cylinder assist

- 5. Material Unloading Door**
 - a. Dimensions: 36.25" x 24.50" x 1.75"
 - b. 2" Insulation
 - c. Guillotine style material cutoff door
 - d. Multi position door

- 6. Controls**
 - a. DM430 display with keypad
 - b. Burner and temperature controls
 - c. Work lights and beacon

- 7. Dump Hoist:**
 - a. Large single scissor style dump hoist
 - b. Capacity Range: 6.4 – 12.9 Tons
 - c. Wired remote with magnet

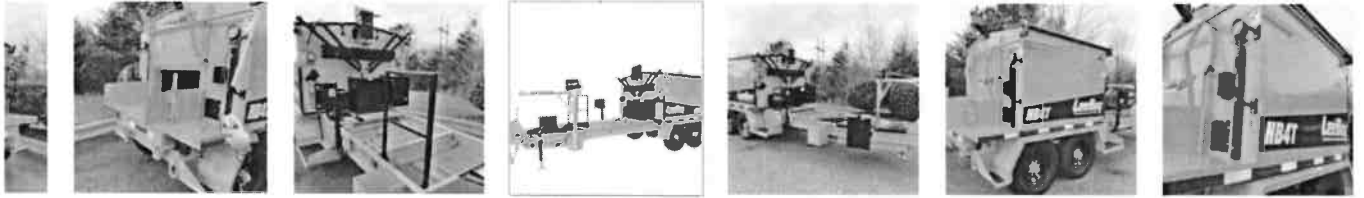
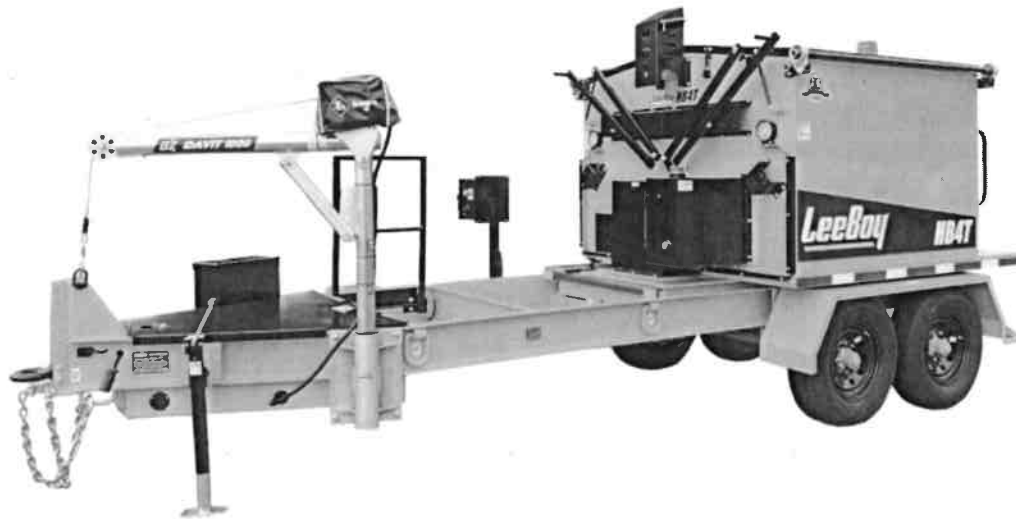

LeeBoy

HB4T

Hot Box

Perfect for the all-inclusive paving contractor and municipalities, the HB4T Hot Box provides a perfectly sized hopper for patching potholes and utility cuts.

Daily tasks can be completed with ease by relying on the trouble-free Beckett burner and the proven reliable user-friendly design. The Hot Box keeps plant material hot and warms cold mix to the optimal working temperature. Uniquely configurable, the customizable options give the contractor the ability

to create a solution specific to their exact needs.

[FIND A DEALER](#)

[Product Specs](#) [Downloads](#) [Product Video](#)

LeeBoy HB4T

Technical Specifications

Dimensions (trailer configuration)

Length: 17' 10"

Width: 8' 9"
Height: 7' 8"
Shipping Weight: 5,000 lbs

Hopper Dimensions (for trailer configuration)

Length: 72"
Width: 64"
Height: 51"
2" Insulation

Material Unloading Doors

Insulated Guillotine style
36.25" x 22.25" x 1.5"
Multi position door

Material Loading Doors

Dual cantilever door
65" x 36.68" x 2"

Dump Hoist

Large single scissor style
Capacity Range: 6.4-12.9 tons
Wired remote with magnet

Heat System

105,000 BTU diesel burner
Diesel Tank: 16 gallons
Thermostatically controlled heating

Overnight Heat

Thermostatically controlled

Batteries

One 12.8V 280AH lithium battery
On-board battery charge
Battery disconnect switch

[DOWNLOAD FULL SPECS](#)

Resources & Downloads

- > [Product Brochure](#)
- > [Product Specifications](#)
- > [Product Line Card](#)

Product Video



Sourcewell 
Quote Form



Effective: **22 February 2024**

Prices in US Dollars

FOB Lincolnton, NC

Hot Box

QUOTED FOR: City of Rice

ACCOUNT NUMBER: _____

Dealer: Romco Carrollton TX

DATE: 4-Oct-24

Sourcewell Contract #: 060122-VTL

MODEL	Capacity	Mounting	LIST PRICE	ORDER NUMBER	CK
HB4T	4 ton	Trailer, Electric Dump, Thermostat Controlled Diesel Heat	\$ 41,986	HB4T	x
STANDARD FEATURES					

See LeeBoy HB4T Hot Box Specifications at: Leeboy.com - Specifications

OPTIONS				
DESCRIPTION	LIST PRICE	ORDER NUMBER	CK	
Spare Tire with Trailer Mount	\$ 780	0000		
Manual Loading Hoist - Davit Crane	\$ 3,871	1028240		
Electric Loading Hoist - Davit Crane	\$ 5,483	1028241	x	
Washdown System with Electric Pump and Hose Reel	\$ 1,956	0000	x	
5lb Fire Extinguisher	\$ 307	1024662		
Wheel Chocks	\$ 621	1021130		
Hydraulic Surge Brake	\$ 3,429	0000		
LeeBoy Plate Compactor - LB5013 Single Direction Plate with Honda Engine	\$ 1,900	0000	x	
Special Option(s) Quoted: Tack Option 30gal with pore valve, 40lb lpg heater	LeeBoy Quoted List Price: \$ 5,200	0000	x	
Extended Warranty Program (Contact factory for specifics or go to www.leeboy.com and view extended program under the warranty tab of the dealer login home page.)				
COMMENTS:	Total List Price		\$ 56,525	
	Sourcewell Discount (10%)		\$ 5,652.50	
	Total Sourcewell List Price		\$ 50,872.50	
	Freight <small>*good for 2 days from the date quoted*</small>		\$ 3,000.00	
			\$ -	
SIGNATURE:			\$ -	
			\$ -	
			\$ -	
	Total Price Delivered to Agency		\$ 53,872.50	



STORE 6817 Corsicana
2290 S I-45
Corsicana, TX 75109
(903)641-4408

Rental Price List

Rate charges begin from time of rental. Major credit card and government-issued ID required for rental. For correct tool availability by location and used equipment for sale, visit www.homedepot.com/rentals

MON 6A- 8P TUE 6A- 8P WED 6A- 8P THU 6A- 8P FRI 6A- 8P SAT 6A- 8P SUN 8A- 8P

1. Cutting & Concrete	Sub Class	4 Hour	Daily	Weekly	Monthly	Deposit
Bolt Cutter 36"	96	\$8.00	\$12.00	\$48.00	\$144.00	\$25.00
Bull Float	54	\$11.00	\$16.00	\$64.00	\$192.00	\$25.00
Circular Saw 7 1/4"	212	\$15.00	\$22.00	\$88.00	\$264.00	\$25.00
Compact Stump Grinder	27	\$100.00	\$143.00	\$572.00	\$1,716.00	\$150.00
Cordless 9" Cut Off Saw	87	\$49.00	\$70.00	\$280.00	\$840.00	\$50.00
Cordless Chainsaw	125	\$43.00	\$61.00	\$244.00	\$732.00	\$75.00
Cordless Reciprocating Saw	61	\$19.00	\$27.00	\$108.00	\$324.00	\$50.00
Electric Cement Mixer 3.5 cu. ft.	50	\$37.00	\$53.00	\$212.00	\$636.00	\$50.00
Electric Cement Mixer 6 cu. ft.	106	\$51.00	\$73.00	\$292.00	\$876.00	\$50.00
Electric Chainsaw 16"	20	\$36.00	\$51.00	\$204.00	\$612.00	\$25.00
Electric Concrete Saw 14"	85	\$42.00	\$60.00	\$240.00	\$720.00	\$100.00
Electric Reciprocating Saw	60	\$15.00	\$22.00	\$88.00	\$264.00	\$25.00
Gas Chainsaw 16"	21	\$43.00	\$61.00	\$244.00	\$732.00	\$50.00
Gas Chainsaw 20"	24	\$50.00	\$71.00	\$284.00	\$852.00	\$50.00
Gas Pole Pruner	26	\$47.00	\$67.00	\$268.00	\$804.00	\$50.00
Jamb Saw	76	\$15.00	\$22.00	\$88.00	\$264.00	\$25.00
Large Tile Saw	101	\$50.00	\$71.00	\$284.00	\$852.00	\$100.00
Light-Weight Concrete Gas Saw 12"	45	\$56.00	\$80.00	\$320.00	\$960.00	\$150.00
Manual Tile Cutter 24"	121	\$13.00	\$19.00	\$76.00	\$228.00	\$25.00
Mini Tile Saw	88	\$22.00	\$31.00	\$124.00	\$372.00	\$25.00
PRO Electric Concrete Saw 12"	37	\$56.00	\$80.00	\$320.00	\$960.00	\$100.00
PRO Gas Concrete Saw 14"	95	\$60.00	\$85.00	\$340.00	\$1,020.00	\$150.00
Paver/Block Saw	49	\$62.00	\$89.00	\$356.00	\$1,068.00	\$100.00
Small Tile Saw	86	\$39.00	\$56.00	\$224.00	\$672.00	\$100.00
Stump Grinder	97	\$121.00	\$173.00	\$692.00	\$2,076.00	\$150.00
Walk Behind Concrete Saw 14"	41	\$67.00	\$95.00	\$380.00	\$1,140.00	\$100.00
2. Drills & Hammers	Sub Class	4 Hour	Daily	Weekly	Monthly	Deposit
11 LB Demolition Hammer	204	\$43.00	\$61.00	\$244.00	\$732.00	\$50.00
20 LB Demolition Hammer	206	\$50.00	\$71.00	\$284.00	\$852.00	\$50.00
27 LB Demolition Hammer	227	\$53.00	\$76.00	\$304.00	\$912.00	\$100.00
Breaker	200	\$67.00	\$96.00	\$384.00	\$1,152.00	\$200.00
Breaker Floor Scraper	268	\$30.00	\$30.00	\$60.00	\$120.00	\$25.00
Cordless Hammer Drill 1/2"	102	\$15.00	\$22.00	\$88.00	\$264.00	\$50.00
Hammer Cart for Small Breaker	111	\$53.00	\$76.00	\$304.00	\$912.00	\$100.00
Hammer Drill 1/2"	108	\$27.00	\$38.00	\$152.00	\$456.00	\$25.00
Mud Mixing Drill 1/2"	235	\$15.00	\$22.00	\$88.00	\$264.00	\$50.00
PRO Breaker	270	\$92.00	\$131.00	\$524.00	\$1,572.00	\$200.00
PRO Small Breaker	201	\$85.00	\$121.00	\$484.00	\$1,452.00	\$200.00
Roto Hammer 1 1/2"	212	\$50.00	\$71.00	\$284.00	\$852.00	\$50.00
Roto Hammer 1"	214	\$43.00	\$61.00	\$244.00	\$732.00	\$25.00
Roto Hammer 2"	225	\$57.00	\$81.00	\$324.00	\$972.00	\$100.00
SDS Max Floor Scraper	266	\$18.00	\$25.00	\$100.00	\$300.00	\$25.00
Small Breaker	203	\$53.00	\$76.00	\$304.00	\$912.00	\$150.00
3. Generators	Sub Class	4 Hour	Daily	Weekly	Monthly	Deposit
2000 Watt Inverter Generator	322	\$50.00	\$71.00	\$284.00	\$852.00	\$150.00
3500 Watt Generator	302	\$50.00	\$71.00	\$284.00	\$852.00	\$150.00
6500 Watt Generator	308	\$65.00	\$93.00	\$372.00	\$1,116.00	\$200.00
4. Plumbing & Pumps	Sub Class	4 Hour	Daily	Weekly	Monthly	Deposit
Auto-Feed Drain Cleaner 100' x 3/4"	466	\$78.00	\$112.00	\$448.00	\$1,344.00	\$100.00
Auto-Feed Drain Cleaner 50' x 1/2"	468	\$61.00	\$87.00	\$348.00	\$1,044.00	\$100.00
Auto-Feed Drain Cleaner 75' x 1/2"	467	\$68.00	\$97.00	\$388.00	\$1,164.00	\$100.00
Cordless Drain Cleaner 35' x 5/16"	486	\$29.00	\$42.00	\$168.00	\$504.00	\$100.00
Drain Camera	463	\$196.00	\$280.00	\$1,120.00	\$3,360.00	\$250.00
Drain Cleaner 100' x 3/4"	485	\$64.00	\$92.00	\$368.00	\$1,104.00	\$100.00
Drain Cleaner 50' x 1/2"	401	\$60.00	\$72.00	\$288.00	\$864.00	\$100.00
Drain Cleaner 75' X 1/2"	480	\$57.00	\$82.00	\$328.00	\$984.00	\$100.00
Drill Unit Drain Cleaner 25' x 5/16"	409	\$29.00	\$42.00	\$168.00	\$504.00	\$50.00
Gas Trash Pump 2"	434	\$55.00	\$79.00	\$316.00	\$948.00	\$100.00
Gas Trash Pump 3"	410	\$62.00	\$89.00	\$356.00	\$1,068.00	\$150.00

Gas Water Pump 1"	427	\$22.00	\$32.00	\$128.00	\$384.00	\$50.00
Manual Drain Cleaner 50' x 1/2"	403	\$29.00	\$42.00	\$168.00	\$504.00	\$50.00
Multi Head Crimper Set	455	\$11.00	\$16.00	\$64.00	\$192.00	\$10.00
Roofers Pump	418	\$18.00	\$25.00	\$100.00	\$300.00	\$25.00
Submersible Pump 2"	414	\$33.00	\$47.00	\$188.00	\$564.00	\$50.00
5. Fastening & Welding	Sub Class 4 Hour		Daily	Weekly	Monthly	Deposit
20V Brad Nailer	548	\$28.00	\$40.00	\$160.00	\$480.00	\$75.00
20V Finish Nailer	568	\$28.00	\$40.00	\$160.00	\$480.00	\$50.00
20V Framing Nailer	594	\$28.00	\$40.00	\$160.00	\$480.00	\$75.00
Air Floor Stapler 15.5 Gauge	563	\$28.00	\$40.00	\$160.00	\$480.00	\$50.00
Air Floor Stapler 18 Gauge	510	\$21.00	\$30.00	\$120.00	\$360.00	\$50.00
Air Framing Nailer	514	\$21.00	\$30.00	\$120.00	\$360.00	\$25.00
Cordless Impact Driver 1/4"	527	\$15.00	\$22.00	\$88.00	\$264.00	\$50.00
Electric Air Compressor 2.6 CFM	581	\$20.00	\$28.00	\$112.00	\$336.00	\$75.00
Welder/Generator	542	\$67.00	\$95.00	\$380.00	\$1,140.00	\$250.00
6. Compactors	Sub Class 4 Hour		Daily	Weekly	Monthly	Deposit
Manual Tamper	605	\$7.00	\$10.00	\$40.00	\$120.00	\$10.00
Vibratory Plate Compactor 14"	603	\$64.00	\$92.00	\$368.00	\$1,104.00	\$150.00
Vibratory Plate Compactor 20"	600	\$68.00	\$97.00	\$388.00	\$1,164.00	\$150.00
7. Painting & Decorating	Sub Class 4 Hour		Daily	Weekly	Monthly	Deposit
Electric Wallpaper Steamer	705	\$27.00	\$38.00	\$152.00	\$456.00	\$50.00
Gun & Hopper	731	\$13.00	\$18.00	\$72.00	\$216.00	\$10.00
Medium Duty Paint Sprayer	728	\$67.00	\$96.00	\$384.00	\$1,152.00	\$150.00
PRO Paint Sprayer	738	\$81.00	\$116.00	\$464.00	\$1,392.00	\$150.00
8. Lawn & Garden	Sub Class 4 Hour		Daily	Weekly	Monthly	Deposit
1 Man Auger	820	\$64.00	\$91.00	\$364.00	\$1,092.00	\$100.00
18in Trencher	864	\$124.00	\$177.00	\$708.00	\$2,124.00	\$250.00
2 Man Auger	822	\$78.00	\$111.00	\$444.00	\$1,332.00	\$100.00
Cordless Hedge Trimmer	910	\$25.00	\$36.00	\$144.00	\$432.00	\$75.00
Cordless String Trimmer	911	\$32.00	\$46.00	\$184.00	\$552.00	\$75.00
Gas Brush Cutter	880	\$34.00	\$49.00	\$196.00	\$588.00	\$50.00
Gas Hedge Trimmer	839	\$32.00	\$45.00	\$180.00	\$540.00	\$50.00
Gas String Trimmer	882	\$32.00	\$46.00	\$184.00	\$552.00	\$75.00
Handheld Blower	908	\$17.00	\$24.00	\$96.00	\$288.00	\$25.00
Hydraulic Brush Hog	930	\$92.00	\$131.00	\$524.00	\$1,572.00	\$150.00
Lawn Roller	833	\$18.00	\$26.00	\$104.00	\$312.00	\$25.00
Light Duty Tiller	803	\$47.00	\$67.00	\$268.00	\$804.00	\$150.00
Log Splitter	870	\$83.00	\$119.00	\$476.00	\$1,428.00	\$150.00
Mantis Tiller	801	\$32.00	\$45.00	\$180.00	\$540.00	\$50.00
Mantis XP Tiller	901	\$40.00	\$57.00	\$228.00	\$684.00	\$50.00
Mid Tine Tiller	805	\$54.00	\$77.00	\$308.00	\$924.00	\$150.00
PRO 1 Man Auger	821	\$85.00	\$121.00	\$484.00	\$1,452.00	\$150.00
Post Hole Digger	826	\$7.00	\$10.00	\$40.00	\$120.00	\$10.00
Rear Tine Tiller	807	\$75.00	\$107.00	\$428.00	\$1,284.00	\$150.00
Self-Propelled Lawnmower	808	\$32.00	\$45.00	\$180.00	\$540.00	\$50.00
Sod Cutter	844	\$85.00	\$121.00	\$484.00	\$1,452.00	\$150.00
Towable Hydraulic Auger	823	\$95.00	\$135.00	\$540.00	\$1,620.00	\$150.00
9. Floor care & Sanding	Sub Class 4 Hour		Daily	Weekly	Monthly	Deposit
Belt Sander	932	\$22.00	\$32.00	\$128.00	\$384.00	\$50.00
Carpet Blower	920	\$22.00	\$32.00	\$128.00	\$384.00	\$25.00
Carpet Cleaner	901	\$27.00	\$39.00	\$156.00	\$468.00	\$50.00
Carpet Cleaner and Detailer	962	\$22.00	\$32.00	\$128.00	\$384.00	\$50.00
Carpet Drying Fan	895	\$7.00	\$10.00	\$40.00	\$120.00	\$25.00
Carpet Kicker	916	\$12.00	\$17.00	\$68.00	\$204.00	\$10.00
Carpet Power Stretcher & Case	912	\$25.00	\$35.00	\$140.00	\$420.00	\$50.00
Coating Removal Tool	897	\$89.00	\$89.00	\$356.00	\$1,068.00	\$25.00
Compact Floor Stripper	924	\$46.00	\$66.00	\$264.00	\$792.00	\$100.00
Concrete Grinder 10" W/Disc	980	\$161.00	\$196.00	\$784.00	\$2,352.00	\$150.00
Concrete Prep Tool	898	\$89.00	\$89.00	\$356.00	\$1,068.00	\$50.00
Drum Floor Sander	905	\$53.00	\$76.00	\$304.00	\$912.00	\$150.00
Drywall Dust Vacuum	994	\$20.00	\$29.00	\$116.00	\$348.00	\$50.00
Drywall Sander	948	\$39.00	\$56.00	\$224.00	\$672.00	\$50.00
Floor Edger 7"	906	\$39.00	\$56.00	\$224.00	\$672.00	\$150.00
Floor Maintainer	909	\$50.00	\$71.00	\$284.00	\$852.00	\$150.00
Floor Polisher	929	\$39.00	\$56.00	\$224.00	\$672.00	\$100.00
Grinder 7"	989	\$25.00	\$36.00	\$144.00	\$432.00	\$25.00
Hard Flooring Cleaner	985	\$66.00	\$94.00	\$376.00	\$1,128.00	\$150.00
Hexpin Surface Prep System	955	\$62.00	\$89.00	\$356.00	\$1,068.00	\$50.00

	Sub Class 4 Hour	Daily	Weekly	Monthly	Deposit	
High Volume Fan	945	\$27.00	\$38.00	\$152.00	\$456.00	\$50.00
Mini Grinder	940	\$16.00	\$23.00	\$92.00	\$276.00	\$25.00
PRO Carpet Blower	964	\$24.00	\$34.00	\$136.00	\$408.00	\$25.00
PRO Drywall Sander	987	\$43.00	\$61.00	\$244.00	\$732.00	\$50.00
PRO Floor Stripper	972	\$71.00	\$101.00	\$404.00	\$1,212.00	\$100.00
Paint Sander	934	\$12.00	\$17.00	\$68.00	\$204.00	\$10.00
Square Buff Floor Sander	903	\$53.00	\$76.00	\$304.00	\$912.00	\$150.00
Tile Roller w/ Wheels	910	\$18.00	\$26.00	\$104.00	\$312.00	\$50.00
Wet/Dry Vacuum 12 Gal	921	\$18.00	\$25.00	\$100.00	\$300.00	\$25.00
10. Other	Sub Class 4 Hour	Daily	Weekly	Monthly	Deposit	
2000 - 3000 PSI Pressure Washer	102	\$61.00	\$87.00	\$348.00	\$1,044.00	\$150.00
300LB Fiberglass Twin Stepladder 14'	149	\$38.00	\$54.00	\$216.00	\$648.00	\$50.00
3500 - 4000 PSI Pressure Washer	104	\$71.00	\$102.00	\$408.00	\$1,224.00	\$150.00
375 LB Fiberglass Stepladder 10'	282	\$22.00	\$31.00	\$124.00	\$372.00	\$25.00
375 LB Fiberglass Stepladder 12'	283	\$23.00	\$33.00	\$132.00	\$396.00	\$50.00
4 Wheel Dolly	136	\$11.00	\$15.00	\$60.00	\$180.00	\$10.00
450LB Material Lift 12'	333	\$57.00	\$81.00	\$324.00	\$972.00	\$150.00
Aluminum Extension Ladder 32'	122	\$36.00	\$51.00	\$204.00	\$612.00	\$50.00
Aluminum Multi Purpose Ladder 26'	285	\$29.00	\$41.00	\$164.00	\$492.00	\$25.00
Appliance Dolly	134	\$21.00	\$30.00	\$120.00	\$360.00	\$25.00
Channel Frame Trailer 5'x8'	336	\$39.00	\$55.00	\$220.00	\$660.00	\$100.00
Compact Extension Ladder 16'	323	\$23.00	\$33.00	\$132.00	\$396.00	\$25.00
Dehumidifier 18 G/Day	138	\$42.00	\$60.00	\$240.00	\$720.00	\$100.00
Drywall Lift 14'	706	\$36.00	\$51.00	\$204.00	\$612.00	\$100.00
Electric Pressure Washer	602	\$33.00	\$47.00	\$188.00	\$564.00	\$50.00
Evaporative Cooling Fan	390	\$54.00	\$77.00	\$308.00	\$924.00	\$100.00
Fiberglass Extension Ladder 24'	118	\$29.00	\$41.00	\$164.00	\$492.00	\$25.00
Fiberglass Extension Ladder 32'	319	\$36.00	\$51.00	\$204.00	\$612.00	\$50.00
Hand Truck	132	\$18.00	\$25.00	\$100.00	\$300.00	\$25.00
Insul Blwr AttiCat GO	210	\$139.00	\$199.00	\$1,393.00	\$5,572.00	\$250.00
Insul Blwr Cellulose	166	\$139.00	\$199.00	\$1,393.00	\$5,572.00	\$250.00
Insul Blwr Fiberglass OR Wool	266	\$139.00	\$199.00	\$1,393.00	\$5,572.00	\$250.00
Loading Ramps	131	\$14.00	\$20.00	\$80.00	\$240.00	\$25.00
Mold Removal Fogger	355	\$20.00	\$29.00	\$116.00	\$348.00	\$50.00
Pallet Jack 6000 LB	372	\$42.00	\$60.00	\$240.00	\$720.00	\$50.00
Rotary Laser Level Kit	380	\$50.00	\$72.00	\$288.00	\$864.00	\$50.00
Solid Wall Trailer 5'x8'	640	\$42.00	\$60.00	\$240.00	\$720.00	\$100.00
Tile & Grout Steam Cleaner	550	\$59.00	\$84.00	\$336.00	\$1,008.00	\$100.00
11. Scaffolding	Sub Class 4 Hour	Daily	Weekly	Monthly	Deposit	
10' High Scaffold Set	22	\$56.00	\$80.00	\$200.00	\$500.00	\$150.00
15' High Scaffold Set	24	\$70.00	\$100.00	\$250.00	\$625.00	\$200.00
5' High Scaffold Set	20	\$42.00	\$60.00	\$150.00	\$375.00	\$100.00
Interior Scaffold 12 ft	15	\$54.00	\$77.00	\$193.00	\$483.00	\$100.00
33. Large Equipment	Sub Class 4 Hour	Daily	Weekly	Monthly	Deposit	
1.5 - 2 Ton Mini Excavator	336	\$269.00	\$359.00	\$1,077.00	\$2,693.00	\$500.00
19' Scissor Lift on Trailer	502	\$229.00	\$229.00	\$687.00	\$1,718.00	\$300.00
2.5 - 3.5 Ton Mini Excavator	588	\$299.00	\$399.00	\$1,197.00	\$2,993.00	\$500.00
24" Trencher	912	\$187.00	\$249.00	\$747.00	\$1,868.00	\$300.00
3.5 - 4 Ton Mini Excavator	407	\$322.00	\$429.00	\$1,287.00	\$3,218.00	\$500.00
35' Towable Boom Lift	509	\$277.00	\$369.00	\$1,107.00	\$2,768.00	\$500.00
36" Trencher	107	\$217.00	\$289.00	\$867.00	\$2,168.00	\$300.00
48" Trencher	954	\$232.00	\$309.00	\$927.00	\$2,318.00	\$300.00
50' Towable Boom Lift	500	\$359.00	\$479.00	\$1,437.00	\$3,161.00	\$500.00
6 x 10 Dump Trailer	387	\$157.00	\$209.00	\$627.00	\$1,568.00	\$300.00
6" Chipper	843	\$232.00	\$309.00	\$927.00	\$2,318.00	\$300.00
7 x 14 Dump Trailer	268	\$172.00	\$229.00	\$687.00	\$1,718.00	\$300.00
Backhoe, Micro (6' Dig Depth)	395	\$247.00	\$329.00	\$987.00	\$2,468.00	\$500.00
Mini Skid Steer	113	\$239.00	\$319.00	\$957.00	\$2,393.00	\$500.00
Skid Steer Tracked, ROC 1400-1900 lb	427	\$329.00	\$439.00	\$1,229.00	\$3,073.00	\$500.00
Skid Steer Tracked, ROC 700-1200 lb	419	\$264.00	\$379.00	\$1,213.00	\$3,033.00	\$500.00
Skid Steer Wheeled, ROC 1000-1200 lb	494	\$262.00	\$349.00	\$1,047.00	\$2,618.00	\$500.00
Skid Steer Wheeled, ROC 1500-1750 lb	325	\$277.00	\$369.00	\$1,107.00	\$2,768.00	\$500.00
Stump Grinder	944	\$239.00	\$319.00	\$1,021.00	\$2,553.00	\$300.00



North Frisco 10PM 75033



North Frisco 10PM 75033

Shop All Services DIY Log In



Hover Image to Zoom

Internet #316821441 Model #DMP610 Rental Category #33 Rental Subcategory #387

6' x 10' Dump Trailer Rental

Rental Pricing for North Frisco #6513

Exact pricing will be determined at the store.

\$157⁰⁰
4-Hours

\$209⁰⁰
Per Day

\$627⁰⁰
Per Week

\$1,568⁰⁰
4 Weeks

Your Deposit will be calculated at checkout. Credit Cards accepted. No Cash.

A **valid identification** is required at pickup.

Call 1-888-266-7228 to schedule jobsite delivery and equipment support.

Models vary based on location and availability.



North Frisco 10PM 75033



North Frisco 10PM 75033

Shop All Services DIY Log In



Hover Image to Zoom

Internet #316821818 Model #322D TP Rental Category #33 Rental Subcategory #268

7' x 14' Dump Trailer Rental

Rental Pricing for North Frisco #6513

Exact pricing will be determined at the store.

\$172⁰⁰

4-Hours

\$229⁰⁰

Per Day

\$687⁰⁰

Per Week

\$1,718⁰⁰

4 Weeks

Your Deposit will be calculated at checkout. Credit Cards accepted. No Cash.

A **valid identification** is required at pickup.

Call 1-888-266-7228 to schedule jobsite delivery and equipment support.

Models vary based on location and availability.



10 b. Discuss and Deliberate the purchase/financing of a new patrol unit

QUOTES for new Patrol Vehicle

From Charles Parson <cparson@ricetx.gov>

Date Mon 10/7/2024 10:48 AM

To Vicki Fisher <vfisher@ricetx.gov>

Cc Mathew Adams <madams@ricetx.gov>; Celeste Martinez <cmartinez@ricetx.gov>

 5 attachments (3 MB)

FORD EXPLORER AWD - GRAY.pdf; FORD EXPLORER AWD- BLACK.pdf; CHEVY TAHOE 2WD.pdf; CHEVY TAHOE 4X4.pdf; FORD F-150 AWD.pdf;

Mrs. Fisher,

Quotes for five different patrol vehicles are attached for City Council to decide from.

Think Healthy, Be Healthy.

Best regards,

Chief Charles Parson

Rice Police Department

305 N. Dallas Street

Rice, TX 75155

903-326-4146

903-326-7426 fax

cparson@ricetx.gov



[Matthew 5:9 Blessed are the peacemakers, for they shall be called the children of God.](#)

CONFIDENTIALITY NOTICE: The information contained in this electronic mail (e-mail) is confidential and/or privileged. This e-mail is intended to be reviewed initially by only the individual named above. If the reader of this page is not the intended recipient or a representative of the intended recipient, then s/he is hereby notified that any review, dissemination, or copying of this e-mail and the information contained herein is prohibited. If this e-mail has been received in error, please notify the sender, then delete the e-mail.

Charles Parson

From: Defender Supply <sales@defendersupply.com>
Sent: Thursday, September 26, 2024 2:01 PM
To: Charles Parson
Subject: Vehicle Estimate #DEF-04577 - Defender Supply

CHARLES PARSON

Thank you for your visit to Defender Supply's Vehicle Configurator. The estimate for the vehicle you customized is below. Please email or call us at sales@defendersupply.com 800-486-3115 if you have any questions or want to see if your department qualifies for additional discounts.

Below is the contact information we have for you, if any of it is incorrect please send an email to sales@defendersupply.com, with your estimate number in the subject line.

Email: cparson@ricetx.gov
Phone: 9033264146
Dept: Rice Police Department
Preferred Dealership:

Estimate #DEF-04577 details:

ford defender utility police interceptor

\$74,576.00

VEHICLE OPTIONS

– 2025 Ford PUI 3.3L Gas Engine AWD

LIGHTBAR/CONTROLLER

– Whelen Visor Light Package— Whelen Front Inner Edge, Tri Color LED Low Profile Visor Light Bar [Red/Blue/White] with Full Across Take Down, Progressing Flash Patterns with Slide Switch, Cruise and Low Power; Includes 100 Watt Speaker and Bracket, Core Controller, Sync Module, Expansion Module and OBDII Canport. * Price Includes Defender Supply Power Distribution, Main Harness and Installation.

CONSOLES

– Console Package— Includes Contoured Steel Police Console With Dual Cup Holder, Arm Rest, Two Magnetic Mic Clips and Base Plate. * Price Includes Installation

ADDITIONAL LIGHTING

– License Plate Lighting

– Mirror Lighting, Side Facing

- Headlight Flasher
- Rear Side Window Lighting
- Push Bumper Lighting
- Dome Light, Front Cabin
- Hatch, Rear Lighting
- Dome Lights, Under Rear Hatch
- Taillight Flasher

PARTITIONS

- Cargo Barrier
- Prisoner Partition

K9 KENNEL

- Nothing Selected

PUSHBUMPER/BRUSH GUARD

- Push Bumper

REAR STORAGE SOLUTION

- Storage Box

ADDITIONAL OPTIONS

- Tint front Driver and Passenger Windows
- Weapon Locks
- Radio Antenna, Two-Way and Coaxial Cable
- Window Guards
- Spot Light

RADAR

- Stalker DSR 2X Radar System

DIGITAL VIDEO CAMERA

- Nothing Selected



New Vehicle - Explorer	
Model	Explorer
Year	2023
SKU	TK23FPIU-MP-B-DUV1
MSRP	\$65,593.00
Inventory	In Stock
Color	Black
MPG	24/33
Engine	2.3L EcoBoost
Transmission	10-Speed Automatic
Drivetrain	AWD
Options	Police Package, Utility Package, etc.
Warranty	3 Year / 50,000 Mile
Financing	Available
Leasing	Available
Delivery	Available
Prep Fee	\$1,000
Destination	\$1,000
Options	\$10,134.09
MSRP	\$75,727.09
Inventory	In Stock
Color	Black
MPG	24/33
Engine	2.3L EcoBoost
Transmission	10-Speed Automatic
Drivetrain	AWD
Options	Police Package, Utility Package, etc.
Warranty	3 Year / 50,000 Mile
Financing	Available
Leasing	Available
Delivery	Available
Prep Fee	\$1,000
Destination	\$1,000
Options	\$10,134.09
MSRP	\$75,727.09



New 2023 Black Ford Explorer PPV Police Interceptor Utility SUV AWD (includes Rear Air), ready to be built as a Marked Patrol Package (Emergency Lighting, Siren, Partition, Window Barriers, etc.), + Delivery, EXPMBIDUV1

\$65,593.00

\$65,593.00
 + 10,134.09
 \$75,727.09

ID: #104961 SKU: TK23FPIU-MP-B-DUV1

Availability:

This vehicle and parts are in stock, but hasn't been upfitted yet. Lead Times vary by location. Unfortunately, this turnkey package can't be purchased online. Please contact us for more details.

Description

Product Reviews

NO RADAR DSR 2X \$6,230.68
 PUSH BUMPER \$1,483.67
 STORAGE BOX \$2,419.74
 \$10,134.09

Charles Parson

From: Defender Supply <sales@defendersupply.com>
Sent: Thursday, September 26, 2024 2:05 PM
To: Charles Parson
Subject: Vehicle Estimate #DEF-03482 - Defender Supply

CHARLES PARSON

Thank you for your visit to Defender Supply's Vehicle Configurator. The estimate for the vehicle you customized is below. Please email or call us at sales@defendersupply.com 800-486-3115 if you have any questions or want to see if your department qualifies for additional discounts.

Below is the contact information we have for you, if any of it is incorrect please send an email to sales@defendersupply.com, with your estimate number in the subject line.

Email: cparson@ricetx.gov
Phone: 9033264146
Dept: Rice Police Department
Preferred Dealership:

Estimate #DEF-03482 details:

chevrolet tahoe

\$75,876.00

VEHICLE OPTIONS

- 2025 Chevrolet Tahoe PPV 2WD *4WD and SSV
Available as Option.

LIGHTBAR/CONTROLLER

- Whelen Visor Light Package— Whelen Front Inner Edge, Tri Color LED Low Profile Visor Light Bar [Red/Blue/White] with Full Across Take Down, Progressing Flash Patterns with Slide Switch, Cruise and Low Power; Includes 100 Watt Speaker and Bracket, Core Controller, Sync Module, Expansion Module and OBDII Canport. *Price Includes Defender Supply Power Distribution, Main Harness and Installation.

CONSOLES

- Console Package— Includes Contoured Steel Police Console With Dual Cup Holder, Arm Rest, Two Magnetic Mic Clips and Base Plate. *Price Includes Installation

ADDITIONAL LIGHTING

- License Plate Lighting
- Mirror Lighting, Side Facing

- Headlight Flasher
- Rear Side Window Lighting
- Push Bumper Lighting
- Dome Light, Front Cabin
- Hatch, Rear Lighting
- Dome Lights, Under Rear Hatch
- Taillight Flasher

PARTITIONS

- Cargo Barrier
- Prisoner Partition

K9 KENNEL

- Nothing Selected

PUSHBUMPER/BRUSH GUARD

- Push Bumper

REAR STORAGE SOLUTION

- Storage Box

ADDITIONAL OPTIONS

- Tint front Driver and Passenger Windows
- Weapon Locks
- Radio Antenna, Two-Way and Coaxial Cable
- Window Guards
- Spot Light

RADAR

- Stalker DSR 2X Radar System

DIGITAL VIDEO CAMERA

- Nothing Selected

Charles Parson

From: Defender Supply <sales@defendersupply.com>
Sent: Thursday, September 26, 2024 2:14 PM
To: Charles Parson
Subject: Vehicle Estimate #DEF-04511 - Defender Supply

CHARLES PARSON

Thank you for your visit to Defender Supply's Vehicle Configurator. The estimate for the vehicle you customized is below. Please email or call us at sales@defendersupply.com 800-486-3115 if you have any questions or want to see if your department qualifies for additional discounts.

Below is the contact information we have for you, if any of it is incorrect please send an email to sales@defendersupply.com, with your estimate number in the subject line.

Email: cparson@ricetx.gov
Phone: 9033264146
Dept: Rice Police Department
Preferred Dealership:

Estimate #DEF-04511 details:

chevrolet tahoe

\$77,980.00

VEHICLE OPTIONS

- 2025 Chevrolet Tahoe PPV 4WD

LIGHTBAR/CONTROLLER

- Whelen Visor Light Package— Whelen Front Inner Edge, Tri Color LED Low Profile Visor Light Bar [Red/Blue/White] with Full Across Take Down, Progressing Flash Patterns with Slide Switch, Cruise and Low Power; Includes 100 Watt Speaker and Bracket, Core Controller, Sync Module, Expansion Module and OBDII Canport. *Price Includes Defender Supply Power Distribution, Main Harness and Installation.

CONSOLES

- Console Package— Includes Contoured Steel Police Console With Dual Cup Holder, Arm Rest, Two Magnetic Mic Clips and Base Plate. *Price Includes Installation

ADDITIONAL LIGHTING

- License Plate Lighting

- Headlight Flasher

- Rear Side Window Lighting
- Push Bumper Lighting
- Dome Light, Front Cabin
- Hatch, Rear Lighting
- Dome Lights, Under Rear Hatch
- Taillight Flasher

PARTITIONS

- Cargo Barrier
- Prisoner Partition

K9 KENNEL

- Nothing Selected

PUSHBUMPER/BRUSH GUARD

- Push Bumper

REAR STORAGE SOLUTION

- Storage Box

ADDITIONAL OPTIONS

- Tint front Driver and Passenger Windows
- Weapon Locks
- Radio Antenna, Two-Way and Coaxial Cable
- Window Guards
- Spot Light

RADAR

- Stalker DSR 2X Radar System

DIGITAL VIDEO CAMERA

- Nothing Selected



Charles Parson

From: Defender Supply <sales@defendersupply.com>
Sent: Thursday, September 26, 2024 2:11 PM
To: Charles Parson
Subject: Vehicle Estimate #DEF-04952 - Defender Supply

CHARLES PARSON

Thank you for your visit to Defender Supply's Vehicle Configurator. The estimate for the vehicle you customized is below. Please email or call us at sales@defendersupply.com 800-486-3115 if you have any questions or want to see if your department qualifies for additional discounts.

Below is the contact information we have for you, if any of it is incorrect please send an email to sales@defendersupply.com, with your estimate number in the subject line.

Email: cparson@ricetx.gov
Phone: 9033264146
Dept: Rice Police Department
Preferred Dealership:

Estimate #DEF-04952 details:

ford f 150 responder

\$79,360.00

VEHICLE OPTIONS

- 2025 Ford F-150 Police Responder 4WD 3.5L V6 EcoBoost

LIGHTBAR/CONTROLLER

- Whelen Visor Light Package— Whelen Front Inner Edge, Tri Color LED Low Profile Visor Light Bar [Red/Blue/White] with Full Across Take Down, Progressing Flash Patterns with Slide Switch, Cruise and Low Power; Includes 100 Watt Speaker and Bracket, Core Controller, Sync Module, Expansion Module and OBDII Canport. *Price Includes Defender Supply Power Distribution, Main Harness and Installation.

CONSOLES

- Console Package— Includes Contoured Steel Police Console With Dual Cup Holder, Arm Rest, Two Magnetic Mic Clips and Base Plate. *Price Includes Installation

ADDITIONAL LIGHTING

- License Plate Lighting

- Headlight Flasher

- Push Bumper Lighting
- Dome Light, Front Cabin
- Taillight Flasher
- Rear Window Traffic Advisor
- Rear Doors Side Window Lighting

PARTITIONS

- Prisoner Partition

K9 KENNEL

- Nothing Selected

PUSHBUMPER/BRUSH GUARD

- Push Bumper

REAR STORAGE SOLUTION

- Bed Mounted Storage Box
- Bed Cover

ADDITIONAL OPTIONS

- Tint front Driver and Passenger Windows
- Weapon Locks
- Radio Antenna, Two-Way and Coaxial Cable
- Window Guards
- Spot Light

RADAR

- Stalker DSR 2X Radar System

DIGITAL VIDEO CAMERA

- Nothing Selected

Financing for Police Patrol Unit

Harmony Bank	5% (if rates come down, this percentage could be lower)
City of Frost	Use their local bank.
City of Richland	Leases
TML Conference	Government Capital (emailed) (Can possibly be bought and payments start at next budget cycle)



12. ADJOURNMENT